

ISSN (Print) : 2277-7261
ISSN (on-line) : 2278-3857

PRATIBHA

INTERNATIONAL JOURNAL OF SCIENCE,
SPIRITUALITY, BUSINESS & TECHNOLOGY
(IJSSBT)

Vol. 5, No. 1, December - 2016

www.ijssbt.org



SHRAM SADHANA BOMBAY TRUST'S
COLLEGE OF ENGINEERING & TECHNOLOGY, BAMBHORI, JALGAON (INDIA)

PRATIBHA : INTERNATIONAL JOURNAL OF SCIENCE, SPIRITUALITY, BUSINESS & TECHNOLOGY (IJSSBT) Vol. 5, No. 1, December - 2016 ISSN (Print) : 2277-7261 ISSN (on-line) : 2278-3857

PRATIBHA
INTERNATIONAL
JOURNAL OF SCIENCE,
SPIRITUALITY,
BUSINESS & TECHNOLOGY
(IJSSBT)

Vol. 5, No. 1, December - 2016

ISSN (Print) : 2277-7261
ISSN (on-line) : 2278-3857

www.ijssbt.org

EDITOR(s) - IN - CHIEF:

Prof. Dr. Kishor S. Wani

Prof. Dr. Sanjay P. Shekhawat





Smt Pratibha Devisingh Patil
Former President of India

**Our inspiration
to impart Quality Education for
societal development**

PRATIBHA

INTERNATIONAL JOURNAL OF SCIENCE, SPIRITUALITY, BUSINESS & TECHNOLOGY

Vol. 5, No. 1, December - 2016 | ISSN (Print) : 2277-7261 | ISSN (On-line) : 2278-3857

PRATIBHA: INTERNATIONAL JOURNAL OF SCIENCE, SPIRITUALITY, BUSINESS AND TECHNOLOGY (IJSSBT)

Pratibha: International Journal of Science, Spirituality, Business and Technology (IJSSBT) is a research journal published by Shram Sadhana Bombay Trust's, COLLEGE Of ENGINEERING & TECHNOLOGY, Bambhori, Jalgaon, MAHARASHTRA STATE, INDIA. College was founded by FORMER PRESIDENT, GOVT. OF INDIA, Honorable Excellency Sau. PRATIBHA DEVI SINGH PATIL.

Shram Sadhana Bombay Trust runs the COLLEGE of ENGINEERING & TECHNOLOGY at Bambhori, Jalgaon, which is the one of the important industrial town & district headquarters of Maharashtra state. The Institute is Accredited by National Assessment and Accreditation Council (NAAC) with CGPA of 2.91 on a seven point scale at B++ Grade, valid for a period of Five Years from 16-09-2016 (Vide letter No: F.19.26/EC(SC-17)/DO/2016/132.1, dated 19-09-2016). The College is ranked as 'A' Grade by North Maharashtra University, Jalgaon, as per its Academic Audit for the Quality Engineering Education. It has received "Lokmat - Corporate Excellence Award" on 28th November 2015, for Brand Excellence in Education. It has also received "Engineering Education Excellence Award-2015", by INDO Global Chamber of Commerce Industries and Agriculture Pune, for the efforts in promoting Quality Education and implementing the higher standards of Technical Education in the field of Engineering. It is awarded as **Best Engineering College of Maharashtra State** by Engineering Education Foundation Pune in year 2008-09.

The College has ten full fledged departments. QMS of the College conforms to ISO 9001:2008 and is certified by JAAZ under the certificate number: 1017-QMS-0117. The college has been included in the list of colleges prepared under Section 2(f) of the UGC Act, 1956 vide letter number F 8-40/2008 (CPP-I) dated May, 2008 and 12(B) vide letter number F.No. 8-40/2008(CPP-I/C) dated september -2010. Bio-Technology, Chemical Engineering, Civil Engineering, Electronics & Tele-Communications and Mechanical Engineering Department have recognized research laboratory for Ph.D. Programs.

Spread over 25 Acres, the campus of the college is beautifully located on the bank of River Girna. The campus is well equipped with important amenities such as classrooms, drawing halls, laboratories, seminar halls, library, computer center, workshops, hostels, canteens, indoor as well as outdoor sports facilities etc.

The International Journal of Science, Spirituality, Business and Technology (IJSSBT) is an excellent, intellectual, peer reviewed journal that takes scholarly approach in creating, developing, integrating, sharing and applying knowledge about all the fields of study in Engineering, Spirituality, Management and Science for the benefit of humanity and the profession.

The reader includes researchers, managers, engineers, curriculum designers administrators as well as developers.

EDITOR(s)-IN-CHIEF

Prof. Dr. K. S. WANI,

M. Tech. (Chem. Tech.), D.B.M., Ph. D.

LMISTE, LMAFST, MOTAI, LMBRSI

Principal,

S.S.B.T.'s College of Engineering and Technology,

P.B. 94, Bambhori,

Jalgaon-425001 Maharashtra, India

Mobile No. +919422787643

Phone No. (0257) 2258393,

Fax No. (0257) 2258392,

Email id: wani.kishor@gmail.com

Prof. Dr. SANJAY P. SHEKHAWAT

Ph.D. (Mechanical Engineering)

Professor and Head,

Department of Mechanical Engineering,

S.S.B.T.'s, College of Engineering and Technology,

P.B. 94, Bambhori,

Jalgaon-425001, Maharashtra State, India

Mobile No. +91 9423621653

Phone No. (0257) 2258393,

Fax No. (0257) 2258392.

Email id : spshekhawat@rediffmail.com

Web Address : www.ijssbt.org/com

Journal Indexing



COSMOS IMPACT FACTOR



RESEARCH BIB

PUBLICATION COMMITTEE

SUHAS M. SHEMBEKAR

Assistant Professor
Electrical Engineering Department
S. S. B. T.'s College of Engineering and Technology, Bambhori, Jalgaon (M.S.)

DHANESH S. PATIL

Assistant Professor
Electrical Engineering Department
S. S. B. T.'s College of Engineering and Technology, Bambhori, Jalgaon (M.S.)

LOCAL REVIEW COMMITTEE

Dr. K. S. Wani

Principal
S.S.B.T.'s College of Engineering & Technology,
Bambhori, Jalgaon

Dr. S.P. Shekhawat

Professor & Head
Department of Mechanical Engineering

Dr. M. Husain

Professor & Head
Department of Civil Engineering

Dr. I.D. Patil

Professor & Head
Department of Bio-Technology

Dr. V.U. Edlabadkar

Professor and Head
Department of Applied Science

Dr. V.R. Diware

Associate Professor & Head
Department of Chemical Engineering

Dr. S.R. Suralkar

Professor & Head Department of
Electronics & elecommunication
Engineering

Dr. G. K. Patnaik

Professor & Head
Department of Computer Engineering

Dr. P. J. Shah

Professor & Head
Department of Electrical Engineering

Dr. U. S. Bhadade

Assistant Professor & Head
Department of Information Technology

Dr. V. S. Rana

Associate Professor & Head
Department of Business Administration

Table of Contents

Volume 5, No. 1, December 2016

- 1) **A review on Nano toxicology of metal oxide nanoparticles ...** 01
Tilottama A. Chaudhari, Er Navneet K. Patil
- 2) **A Study of Agriculture Subsidy and its Impact on Agriculture Sector with Reference to Jalgaon District...** 06
Dr. Harshal Anil Salunkhe
- 3) **Algorithms For Energy Efficient Routing of Mobile & Wireless Sensor Networks...** 11
Reena Nibandhe, Dr.K.Krishna Naik
- 4) **Characterization of Voltage Sag due to Faults and Induction Motor Starting...** 15
P. R. Bharambe, S. S. Jadhao
- 5) **Man is the Universe...** 22
Pujyasri Bhikshamaiah Guruji
- 6) **Necessity of Spiritual Research For Sustainable Development...** 24
Vishal Rana
- 7) **On realization of cosmic energy and on realization of natural wisdom ..** 31
V. Anantha Padmanabhan
- 8) **Performance of Evaporators and Various Parameters: A Review...** 34
Aijaz Husain, Kalpesh Patil, Dr. S. A. Thakur
- 9) **Review of Dimple Tube Double Pipe Heat Exchanger Design...** 38
Chetan Kharche, Sushila Pawade, Dr. V. R. Diware
- 10) **Spiritual Research: The Role Of Researchers In Shaping The Society”...** 42
BK (Dr.) Subhash Chandra
- 11) **Strength Appraisal of Blended Concrete...** 47
Lomesh S. Mahajan, S.R.Bhagat, S.M.Pore
- 12) **Transforming Education and Mobile Internet Connectivity: A pilot study...** 52
Dr. Saroj B Patil

A review on Nano toxicology of metal oxide nanoparticles

¹*Tilottama A. Chaudhari*

¹P.G. Student, Department of Mechanical Engineering, S.S.B.T.'s, C.O.E.T., Bambhori, Jalgaon
tilottamachaudhari7@gmail.com

²*Er Navneet K. Patil*

²Associate Professor, Department of Mechanical Engineering, S.S.B.T.'s, C.O.E.T., Bambhori, Jalgaon
navneetkpatil@gmail.com

ABSTRACT:

Nanotechnology play a prominent role in our economy. Used of nanaomaterials increased poses potential human health risk. Therefore it is critical to understand nature and origin of the toxicity imposed by nanomaterial. This paper discusses synthesis, characterization and toxicity of metal oxide nanoparticle. There are two toxicities are in vitro and in vivo of its oxide. These oxide are discussed including a consideration of a factor important of safe use of these nanomaterials. In these article toxicity of metal oxide are widely use in industry and bio technology. Nanoparticle toxicity is related to the oxidative stress and alteration of calcium homeostasis cellular signally events. Nano technology is express to address the toxicological activities of nanoparticles and there products to determine whether and to human health ,and define as the study of the mechanism of the toxic effect of nanoparticles on living organism. The help of knowledge of nanotoxicological study will be the base for designing safe nano materials in different biological system. These paper consist of the section with the brief introduction ,the synthesis of metal oxide nonoparticle. Nonotoxicity of metal oxide of nanoparticle etc.

Keywords: *Nanotoxicity; metal oxide nanoparticles; biogenic nanoparticles ;Cytotoxicity ;*

i] INTRODUCTION:

Metal oxide nanoparticles have wide application in technology field. There use as semiconductor electroluminescent or thermo electric material, but they are also use in bio medical application as a drug delivery system or treatment and diagnosis and in environmental applications. The classical methods for obtaining metal oxide nanoparticle are based on physical techniques that employ hazardous and negative effect on the environment. The metal oxide nanoparticle produce increase recently because no well process for development of engineered material. [1] The study of nano technology involves the control of matter on atomic and molecular scales .

Nano sized materials are increasingly used in the fields of industry, science, pharmacy, medicine, electronics, communication and consumer products. The “nano” is derived from the Greek word “nanos” meaning “dwarf” [9]. A nanomaterial (NM) defined as a substance with at least one dimension <100 nm in length. There are numerous nano-sized materials in our life. They can take different forms such as tubes, rods, wires or spheres. Depending on their origin, they can be categorized as either engineered or incidental NMs. Engineered nanoparticles (NPs) are particles generated to use the size-related properties inherent in the nanoscale (e.g. conductivity, spectral properties, biodistribution). Incidental NPs, are defined as particles either from unintended anthropogenic sources (e.g. combustion derived) or of natural origin (e.g., particles generated in forest fires). Engineered NMs including NPs and nanofibres are also categorized into four classes which

include carbon based materials, metal-based materials

Nanotechnology is being applied in diverse fields, including extensions of conventional device physics a new approaches based upon molecular self-assembly, the development of novel materials with dimensions on the nanoscale, and even the direct control of matter on the atomic scale. The application of nanotechnology in biology (nanobiotechnology) encompasses development of nanomaterials for delivering and monitoring biologically active molecules, disease staging, therapeutical planning, surgical guidance, neuro-electronic interfaces, and electronic biosensors.

Nanotoxicology is the study of the toxicity of NMs. It has emerged only recently, years after the beginning of nanotechnology that is considered one of the key technologies of the 21st century, when numerous NMs had already been introduced into some industrial processes and consumer products. Donaldson et al. [10] quoted "discipline of nanotoxicology would make an important contribution to the development of sustainable and safe nanotechnology". Growing concerns about the nanotoxicology were derived from prior experiences with air pollution [11] and asbestos [12]. Nowadays many NPs, for example carbon nanotubes which are much smaller than asbestos, might have asbestos-like effects on cells. Nanotoxicology is an emerging field that builds upon previous work on airborne particle toxicity. Given (1) fixed particle mass, (2) unitary density, and (3) particle surface bioreactivity, nanoparticles possess better tissue penetration and higher biological potency than coarse (2.5–10 μm) and fine (<2.5 μm) particles.[2] The increasing the production and use of metal oxide nanoparticles in numerous application leads to adverse effect on health.

Silver nanoparticles are the most studied metallic nanoparticles but their cytotoxicity and genotoxicity are not fully understood [5,6]. The toxicity of more complex nanostructures, such as graphene and carbon nanotubes, is also uncertain [7]. This review describes the biogenic synthesis of important metal oxide nanoparticles and their cytotoxicity *in vivo* and *in vitro*. The safety implications and environment effects of these nanoparticles are also discussed.

ii] NANOTOXICITY OF METAL OXIDE NANOPARTICLE:

Few paper have reported these nanoparticles have been investigated. The literature discusses the synthesis and characterization of metal oxide nanoparticle. The metal oxide nanoparticles develop applications either by biogenic or classical method and investigation of environmental toxicity of these nanoparticle. Nanotoxicology of these material should be further characterized.

A) Bismuth Trioxide (Bi_2O_3) Nanocrystals

Bismuth trioxide is not toxic to human tissue ionic bismuth is reduce by sodium borohydride is then oxidized at high temperature. NO report have described the toxicity of Bi_2O_3 nanoparticles which indicates necessity of investigating this area of nanotoxicology .

B) Cobalt oxide (Co_3O_4) Nanocrystals

Demonstrated the toxicity of (Co_3O_4) in BEAS-2B cells which are model of areaway epithelium of normal lungs tissues .(Co_3O_4) nanoparticles induces cytotoxicity morphological transformation and genotoxicity in Balb3T3 cells.

Previous reports suggested that commercial bare (Co_3O_4) nanoparticles associated to a protein corona. Lower *in vitro* toxicity was absorb while simulating both Th1 and Th2 *in vivo* antibody responses which indicate that (Co_3O_4) nanoparticles may be use as vaccine adjuvant[13]. That's why easily finding for biogenic (Co_3O_4) nanoparticles because they are naturally capped with protein the biogenic synthesis process.

C) Ironoxide ($\text{Fe}_2\text{O}_3, \text{Fe}_3\text{O}_4$) Nanoparticles

Magnetite (Fe_3O_4) and Hematite(Fe_2O_3) are iron oxide nanoparticles have us for biomedicle and industrial application[14,15]. The toxicity of ironoxide can be attributed to the ROS induction of oxidative stress. Most paper have describe the *in vitro* and *in vivo* toxicity of chemically synthesized ironoxide nanoparticles. This result demonstrated the bio technological and nanotechnological potential of bacterial mahnetic nanoparticles.

D) Atimoney Oxide (Sb_2O_3) Nanoparticles

Antimony trioxide(Sb_2O_3) is primarily use in rubber, paper , pigments , adhesives ,plastics among other materials. Previous paper reported the toxicity of (Sb_2O_3) of nanoparticles

on the proliferation of human hematopoietic progenitor cells. Antimony trioxide treatment was associated with the induction of ROS and differentiation markers.

E) Silica (SiO₂) Nanoparticles

The toxicity of commercial available SiO₂ nanoparticles was investigated in the RAW 264.7 mouse macrophage cell line. Nanotoxic effect of (SiO₂) nanoparticles was significantly attenuated by the capsaicin treatment which indicates the oxidative stress mechanism for toxicity of silica nanoparticles.

iii] BIOGENIC SYNTHESIS OF METAL OXIDE NANOPARTICLES:

This section describes the biogenic green approaches to synthesize different nanoparticles. These nanoparticles are important for technological, biomedical and environmental applications.

A) Cobalt Oxide (Co₃O₄) Nanocrystals

The classical methods of synthesis are solvothermal and thermal decomposition and the use of templates. These synthetic routes are costly, time-consuming and toxic. Previous paper describe the synthesis of Co₃O₄ nanoparticles using marine bacterium *Brevibacterium casei* in which the study of quantitative and qualitative analyses that were conducted during the biogenic synthesis indicated the synthesizability of the micromechanical properties of cells to the surrounding toxic environment [16].

B) Copper Oxide (Cu₂O) Nanoparticles

Copper oxide (Cu₂O) nanoparticles (10–20 nm) were synthesized at room temperature using the baker's yeast *Saccharomyces cerevisiae* [17]. Copper and copper oxide nanoparticles are used in optical and electronic application and are a promising antimicrobial agent. Application of biogenic synthesis of copper based nanoparticles describe in various research paper. Copper oxide nanoparticles were obtained by reduction of copper sulfate by the reductase enzymes of the microorganism. The biogenic synthesis of copper oxides was performed using *Penicillium aurantiogriseum*, *P. citrinum* and *P. waksmanii* isolated from soil [18].

C) Antimony Oxide (Sb₂O₃) Nanoparticles

As an inorganic semiconductor compound, antimony (III) oxide (Sb₂O₃) has

several applications in technology and in chemical catalysis [19]. Jha *et al.* [20,21] reported the low-cost reproducible biosynthesis of Sb₂O₃ nanoparticles at room temperature in the presence of baker's yeast (*S. cerevisiae*). Different characterization techniques revealed the formation of nanoparticles in a face-centered cubic unit cell structure, with an average size of 3–12 nm [20].

D) Titanium Dioxide (TiO₂) Nanoparticles

TiO₂ nanoparticles have important environmental, technological and biomedical applications [22,23]. Jha and Prasad [24] reported the reproducible room temperature biosynthesis of TiO₂ nanoparticles (10–70 nm in size) by *Lactobacillus* sp. that were obtained from yogurt and probiotic tablets. In the presence of suitable carbon and nitrogen sources, *Lactobacillus* or yeast cells interact with a TiO(OH)₂ solution to produce TiO₂ nanoparticles (8–35 nm) with few aggregates. *Lactobacilli* have a negative electrokinetic potential, which is suitable for the attraction of cations, a step that is required for the biosynthesis of metallic nanoparticles.

E) Uraninite (UO₂) Nanoparticles

The reduction of soluble uranium salts by microbial agents represents an important part of the geochemical cycle of this metal and highlights a mechanism for the bioremediation of uranium contamination [28,29]. Nanoparticles of UO₂ are important for nuclear applications. The average particle size was 3 nm, as determined by high-resolution transmission electron microscopy (HRTEM) and X-ray absorption spectroscopy.

iv] CONCLUSION:

These nanoparticles have been considered for diverse applications in biotechnology, catalysis, environmental bioremediation, optics, electronics, and cell energy and in the medical and pharmaceutical sciences. The applications of metal oxide nanoparticles have recently increased. The biogenic synthesis of metal oxide nanoparticles has emerged as an attractive alternative. Metal oxide nanoparticles can be obtained from different organisms such as plant extract, fungi, bacteria, algae, and actinomycetes [30]. This work reports the recent development in the use of green methods to obtain different types of metal oxide nanoparticles that can be used in a wide range of applications.

To use metal oxide nanoparticles (either synthesized by traditional or green methods), it is necessary to investigate their potential toxicity. The effect of metal oxide nanoparticles on humans and the environment is a topic that has received increasing interest and debate [31]. The reviewed literature indicates that the potential toxicities of these nanomaterials have not been completely addressed. Most research focuses on the toxicity of chemical or physical synthesized metal oxide nanoparticles. There are few reports that characterize the nanotoxicity of biogenic metal oxide nanoparticles. Based on published papers, the clearly determination of the similarities and differences, in terms of toxicity, of metal oxide nanoparticle obtained by traditional methods and by biogenic routes can be considered complex. This complexity is due to the different routes of nanoparticles synthesis, their different size, presence or absence of capping molecules, diverse kinds of toxicity evaluation tests, and lack of deeper studies of nanotoxicity of biogenic nanoparticles. Therefore, the potential toxic effects of biogenically obtained nanoparticles should be investigated further.

The literature suggests that nontoxicity is related to (i) the possible release of (toxic) ions from metallic nanoparticles and (ii) the oxidative stress caused by the intrinsic characteristic of the nanoparticle (morphology, surface charge, size and chemical surface composition) [31]. Further studies are required to understand these mechanisms. Finally, the toxicity of nanoparticles can differ depending on the experimental method employed [31]. Nanoparticles themselves can interfere with many tests, and it is often necessary to adapt the protocol to obtain reliable results [32,34]. A standardization of toxicity protocols, long-term study of nanoparticle toxicity and the fate of these nanomaterials in human tissue and in the environment need to be further investigated.

REFERENCES:

- [1] Amedea B. Seabra, Nelson Duran "Nanotoxicology of metal oxide Nanoparticles" published: 3 June 2015
- [2] Yue-Wern Huang, Chi-Heng Wu and Robert S. Aronstam "Toxicity of Transition metal oxide nanoparticles: Recent insights from in vitro Studies" published: 25 octo 2010
- [3] Yuliang Zhao, Bing Wang, Weiyue Feng, Chunli Bai "Nanotoxicology: Toxicological and biological activities of nanomaterial"
- [4] Galdiero, S.; Falanga, A.; Vitiello, M.; Cantisani, M.; Marra, V.; Galdiero, M. Silver nanoparticles as potential antiviral agents. *Molecules* **2011**, *16*, 8894–8918.
- [5] Durán, N.; Guterres, S.S.; Alves O.L. *Nanotoxicology: Materials, Methodologies, and Assessments*; Springer: New York, NY, USA, 2014; p. 412.
- [6] De Lima, R.; Seabra, A.B.; Durán, N. Silver nanoparticles: A brief review of cytotoxicity and genotoxicity of chemically and biogenically synthesized nanoparticles. *J. Appl. Toxicol.* **2012**, *32*, 867–879.
- [7] Seabra, A.B.; Paula, A.J.; de Lima, R.; Alves, O.L.; Durán, N. Nanotoxicity of graphene and graphene oxide. *Chem. Res. Toxicol.* **2014**, *27*, 159–168.
- [8] Arora S, Rajwade JM, Paknikar KM, *Nanotoxicology and in vitro studies: The need of the hour*, *Toxicol Appl Pharm* 258(2), 151-165, 2012.
- [9] Singh N, Manshian B, Jenkins GJS, Griffiths SM, Williams PM, Maffei TGG, Wright CJ, Doak SH, *NanoGenotoxicology: The DNA damaging potential of engineered nanomaterials*, *Biomaterials* 30(23-24), 3891-3914, 2009.
- [10] Donaldson K, Stone V, Tran CL, Kreyling W, Borm PJA, *Nanotoxicology*, *Occup Environ Med* 61(9), 727-728, 2004.
- [11] Dockery DW, Pope CA, Xu X, Spengler JD, Ware JH, Fay ME, Ferris Jr BG, Speizer FE, *An association between air pollution and mortality in six US cities*, *N Engl J Med* 329(24), 1753-1759, 1993.
- [12] Kane AB, Hurt RH, *Nanotoxicology: the asbestos analogy revisited*, *Nat Nanotech* 3(7), 378-379, 2008.
- [13] Cho, W.-S.; Dart, K.; Nowakowska, D.J.; Zheng, X.; Donaldson, K.; Howie, S.E.M. Adjuvanticity and toxicity of cobalt oxide nanoparticles as an alternative vaccine adjuvant. *Nanomedicine* **2012**, *7*, 1495–1505.
- [14] Haddad, P.S.; Seabra, A.B. Biomedical applications of magnetic nanoparticles. In *Iron Oxides: Structure, Properties and Applications*; Martinez, A.I., Ed.; Nova Science Publishers, Inc.: New York, NY, USA, 2012; Volume 1, pp. 165–188.
- [15] Seabra, A.B.; Haddad, P.S.; Duran N. Biogenic synthesis of nanostructured iron compounds: Applications and perspectives. *IET Nanobiotechnol.* **2013**, *7*, 90–99.
- [16] Kumar, U.; Shete, A.; Harle, A.S.; Kasyutich, O.; Schwarzacher, W.; Pundle, A.; Poddar, P. Extracellular bacterial synthesis of protein functionalized ferromagnetic Co₃O₄ nanocrystals and imaging of self-organization of bacterial cells under stress after exposure to metal ions. *Chem. Mater.* **2008**, *20*, 1484–1491
- [17] Prasad, K.; Jha, A.K.; Prasad, K.; Kulkarni, A.R. Can microbes mediate nano-transformation? *Indian J. Phys.* **2010**, *84*, 1355–1360.
- [18] Honary, S.; Barabadi, H.; Gharaeifathabad, E.; Naghibi, F. Green synthesis of copper oxide nanoparticles using *Penicillium aurantiogriseum*, *Penicillium citrinum* and *Penicillium waksmanii*. *Digest J. Nanomat. Biostruct.* **2012**, *7*, 999–1005.
- [19] Vukovic, M.; Brankovic, Z.; Poleti, D.; Recnik, A.; Brankovic, G. Novel simple methods for the synthesis of single-phase valentinite Sb₂O₃. *J. Sol-Gel Sci. Technol.* **2014**, *72*, 527–533.
- [20] Jha, A.K.; Prasad, K.; Prasad, K. Biosynthesis of Sb₂O₃ nanoparticles: A low-cost green approach. *Biotechnol. J.* **2009**, *4*, 1582–1585.
- [21] Jha, A.K.; Prasad, K.; Prasad, K. A green low-cost biosynthesis of Sb₂O₃ nanoparticles. *Biochem. Eng. J.* **2009**, *43*, 303–306.



- [22] Seabra, A.B.; Duran, N. Nitric oxide-releasing vehicles for biomedical applications. *J. Mat.Chem.* **2010**, *20*, 1664–1637.
- [23] Goh, P.S.; Ng, B.C.; Lau, W.J.; Ismail, A.F. Inorganic nanomaterials in polymeric ultrafiltration membranes for water treatment. *Sep. Purif. Rev.* **2015**, *44*, 216–249
- [24] Jha, A.K.; Prasad, K. Biosynthesis of metal and oxide nanoparticles using *Lactobacilli* from yoghurt and probiotic spore tablets. *Biotechnol. J.* **2010**, *5*, 285–291.
- [25] Lovley, D.R.; Phillips, E.J.P. Bioremediation of uranium contamination with enzymatic uranium reduction. *Environ. Sci. Technol.* **1992**, *26*, 2228–2234.
- [29] Lovley, D.; Phillips, E.J.P. Reduction of uranium by *Desulfovibrio desulfuricans*. *Appl. Environ. Microbiol.* **1992**, *58*, 850–856.
- [30] Golinska, P.; Wypij, M.; Ingle, A.P.; Gupta, I.; Dahm, H.; Rai, M. Biogenic synthesis of metal nanoparticles from actinomycetes: Biomedical applications and cytotoxicity. *Appl. Microbiol. Biotechnol.* **2014**, *98*, 8083–8097
- [32] Dasari, T.P.; Pathakoti, K.; Hwang, H.-M. Determination of the mechanism of photoinduced toxicity of selected metal oxide nanoparticles (ZnO, CuO, Co₃O₄ and TiO₂) to *E. coli* bacteria. *J. Environ. Sci.* **2013**, *25*, 882–888.
- [33] Ko, K.-S.; Kong, I.C. Toxic effects of nanoparticles on bioluminescence activity, seed germination, and gene mutation. *Appl. Microbiol. Biotechnol.* **2014**, *98*, 3295–3303

A Study of Agriculture Subsidy and its Impact on Agriculture Sector with Reference to Jalgaon District

Dr. Harshal Anil Salunkhe

Dept. of Business Administration, SSBT's COET, Bambhori, Jalgaon
harshal.salunkhe@gamil.com

ABSTRACT:

The agriculture subsidies are classified as per nature direct & indirect form. The government gives lots of amount of subsidy to agriculture sector but growth of agriculture sector is very slow as compare to other sector in India. In this paper researcher has study the nature of subsidy, its distribution process & its impact on agriculture sector with reference to Jalgaon district with help of primary & secondary data.

Keywords- Agriculture, Subsidy, Impact & Jalgaon District

Introduction

The agriculture subsidy is common phenomenon of every country; its percentage varies as per the numbers of dependence on agriculture sector within country. The agricultural subsidies mean any kind of monetary and non-monetary help from government to agricultural sector i.e. An agricultural subsidy is a governmental subsidy paid to farmers and agribusinesses to supplement their income, manage the supply of agricultural commodities, and influence the cost and supply of such commodities. The Indian Government also gives lot of amount of subsidy to agriculture sector in direct & indirect form in total amount of subsidy is Rs. 55,339.76 crore. & it increases up to Rs. 1, 15,952.20 crore in 2008-09.

In this study researcher has study about nature of agriculture subsidy & its impact on agriculture sector with reference to Jalgaon district with help of primary & secondary data. For this study researcher has design one hypothesis. The Government Subsidies have helped to increase the productive capacity of famers. For testing of hypothesis researcher used two sample T test with help of minitab software.

About Jalgaon Ditriect

Jalgaon District is situated in the north-west section of the state of Maharashtra. It is surrounded by Satpuda mountain ranges in the north, Ajanta mountain ranges in the south. Jalgaon is rich in volcanic soil which is well suited for cotton production. It is a major business center for tea, gold, pulses, cotton and bananas. Jalgaon receives about 700 mm rainfall during monsoons, which is followed by pleasant temperature in winter. The principal natural characteristic is the Tapti River. Unlike the rest of the Deccan, whose rivers rise in the Western Ghats and flow eastward to the Bay of Bengal, the Tapti flows westward from headwaters in eastern Maharashtra to empty into the Arabian Sea. The Tapti receives thirteen principal tributaries in its course through Khandesh. None of the rivers is navigable, and the Tapti flows in a deep bed which historically made it difficult to use for irrigation. Most of Khandesh lies south of the Tapti, and is drained by its tributaries the Girna, Bori and Panjhra. The alluvial plain north of the Tapti contains some of the richest tracts in Khandesh, and the land raises towards the Satpuda hills

The major crops produced in Jalgaon District are banana (In Maharashtra Jalgaon ranks no.1 in banana production and most hector area of banana in Jalgaon 32,000 hector) cotton, sorghum, wheat, millet, lime, groundnut and sugarcane. Jalgaon is also known for its gold quality. The Jalgaon District produces 16% of the total banana production in India. It is also one of the world largest producers of banana. As per Maharashtra State banana producer cooperative federation (Maha Banana), total land cultivated is 66% (49,000 Hectors) in this District. After banana, cotton is another important crop in the District as economical prospective cotton is grown on 1/5 of total cultivated land in District. Sorghum is important food grain in this District.

In Jalgaon District farmer gets subsidies from center & state government through various schemes. The farmers in Jalgaon District

receiving subsidies on micro irrigation, seeds, fertilizers, electricity bills, farm equipments, crop insurance, farm credit, horticulture, solar energy, for building warehouse, export subsidies, training, study tours, natural disaster, soil testing, food processing and subsidies on selected crops like cotton. The farmers in District getting subsidies on agricultural allied business like goat farming, poultry farm, honey bee and fishing etc.

Nature of Agricultural Subsidies in India

The subsidy is divided in two parts in India direct and indirect forms. The researcher has discuss both form one by one.

I. Direct

The direct form of subsidies means, subsidies directly getting hands of farmers either in form of money or kind. In form of money he gets following benefits.

The farmers get subsidiaries interest rate crop loan. In Maharashtra crop loan interest rate is only 6% and if farmers pay regularly, he gets 2% rebate i.e. interest rate on crop loan only 4%. In 2006-07 Government of India gives 100% debt relief scheme for farmers due to farmer's suicides in India. Government of India provides various farm credit policies regarding agricultural credit in India like.

i. Credit

1) Farm Credit Package

The flow of agricultural credit since 2003-04 has consistently exceeded the target. Agricultural credit flow has increased from Rs.86981 crore in 2003-04 to Rs. 468291 crore in 2010-11.

2) Interest Subvention to Farmers

Government of India announced an interest subvention scheme in 2006-07 to enable banks to provide short term credit to agricultural (crop loan) up to Rs.3 lakh at 7% interest to farmers.

ii. Training and Extension

The government provides subsidies for training to farmers regarding increase production. On training of group of 50-150 farmers on seeds production and seed technology, government of Maharashtra provides Rs.15000/- under seed village programme. There are so many

programme arrange by State and Central government.

iii. For Building Warehouse

To building warehouse for storage of food grain government provides 35 % of direct subsidies to famer and 65% of amount contributed by farmers.

iv. Export Subsidies

Government provides subsidies to farmers for export of agricultural commodities and foods.

II. Indirect

Indirect for of subsidies means Government provides subsidies not in hand of famers it gives through middle man. The government provides subsidies on each every recourse required by agricultural production. The list of resources is as follows,

i. Irrigation

On the irrigation government provides subsidies. The Karnataka government provides up to 90% of subsidies on irrigation. Micro irrigation scheme (Drip system) is Centrally Sponsored Scheme under which out of the total cost of the System, 40% will be borne by the Central Government, 10% by the State Government and the remaining 50% will be borne by the beneficiary either through his/her own resources or soft loan from financial institution.

ii. Farm Equipment

The government gives subsidies to farmers on purchased of farms equipment. On purchase of tractor up to 40 BH government of Maharashtra gives Rs.45000/- or 25% of the cost whichever is less. On purchase of tiller government of Maharashtra gives Rs. 45000/- 40% of the cost whichever is less for 8BHP or Rs.25000/- or 40% of the cost whichever is less for less than 8BHP.

iii. Seeds

The government provides subsidies on selected seeds as per need of farmers and as per geographical area. The state government of Punjab has decided to give subsidies on these hybrid seeds to farmers as a result of which HYV seeds would be made available at a rate

ranging from Rs. 87.50 per kg to Rs. 112.50 per kg after subsidy in 2013-14.

iv. Electricity

The government provides electricity to farmers on subsidized rate or some amount money is pays on behalf of famers to Electricity Company. This year Maharashtra state government pays 50% of electricity bills of famers.

v. Solar Energy

For purchase of solar pump government gives 40% of the cost is subsidized and the rest 60% of the cost is eligible for a soft loan. However the margin to be paid by the beneficiary (out of the 60%) is decided as per RBI norms. The repayment period of the loan is 5 years. The interest rates are also as per RBI norms.

vi. Crop Insurance

Government provides crop insurance protection to farmer for protection against losses due to natural disaster. In this scheme farmers pay some amount of money for crops insurance and remaining amount paid by government. Under National Agricultural Insurance Scheme insurance protection for notified food crops, oil seeds and annual horticulture commercial crop, 10% of subsidies on premium is provide to small and medium farmers.

vii. Diesel

With rainfall deficit still prevalent in most parts of the country, government announced a diesel subsidy for irrigation in states where rainfall shortage is more than 50 per cent to protect the standing kharif crop.

viii. Fertilizers

The government provides subsidies on fertilizers like NPKS. The names of some fertilizers are Urea, Ammonium Nitrate, Ammonium Sulfate, Calcium Nitrate, Diammonium Phosphate, Monoammonium phosphate, Triple Super Phosphate, Potassium Nitrate and Potassium Chloride. These are fertilizers available to famers on subsidized rate by government.

I. How To Distribute Subsidy To Farmer

The direct subsidies are given by government to farmers through the bank. It includes crop finance, to make well in farm, compensation for losses due to natural disaster.

The documents require for getting direct subsidy

- Adhar Card/ Ration Card
- Residence Proof
- Inquest report by Government officer (Village Secretary)
- Saving Account in Bank

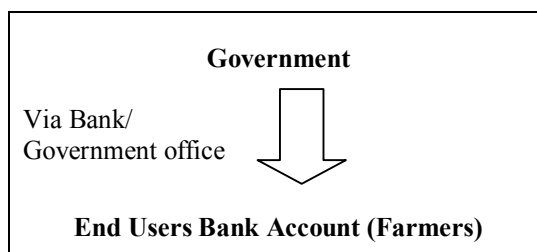

Figure No.1- Direct Distribution of Subsidy to Farmers

In India agricultural subsidies are distributed on centralized basis. The indirect form of subsidies are distributed by government to agricultural vendor (mediator) e.g. Fertilizer Company, Pipe Company, Mechanized farm Equipment Company and Electricity distribution company and through agricultural vendor to end users i.e. farmer

The farmer want to buy tractor from tractor dealer, it would cost Rs. 5,00,000/-. He has pay Rs.4,50,000/- to tractor dealer and Rs.50,000/- is paid by government on behalf of farmer to dealer. Another example regarding electricity subsidies, Rate of per unit electricity Rs. 6 but for farmers it will be only Rs.4 and remaining Rs. 2 paid by government to electricity board on behalf of farmer. In special case, i.e. losses of crops due to natural disaster total amount of electricity bill paid by government to electricity board on behalf of farmer. The same type of method is adopted in

Table No. 1 -Years Area, Production & Productivity of Jalgaon District. (Area in "00" ha, Production in "00" Tons, Productivity in Kg /ha)

Sr · N o	Year	Area	Produ ction	Producti vity
1	2001-02	13235	24641	6530
2	2002-03	14009	27111	8995
3	2003-04	14429	22856	8638
4	2004-05	14260	27815	7938
5	2005-06	14354	30159	8100
6	2006-07	15623	36332	9462
7	2007-08	15365	42473	9943
8	2008-09	11633	25053	8397
9	2009-10	15072	30179	9589
10	2010-11	15699	38549	10738

Source- <http://www.mahaagri.gov.in/>

fertilizers and Pipe Company for irrigation.

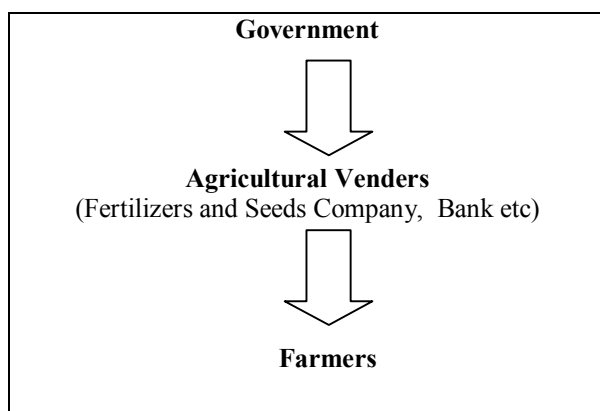

Figure No. 2- Indirect Distribution of Subsidy to Farmers

Agriculture Production of Jalgaon District

In 2001-02 total agricultural production of Jalgaon District is 24641 tons, the total cultivated area is 13235 hectares and productivity is 6530 Kg/ hecter. And in 2010-11 total agricultural production of Jalgaon District is 38549 tons, the total cultivated area is 15699 hectares and productivity is 10738 Kg/ hecter. Above figures shows that agricultural production of Jalgaon District is continuously increases and most of the farmers in Jalgaon District received subsidy from more than 9 years. It means that subsidy has help full for agricultural growth of Jalgaon District.

Testing of Hypothesis

H0: The government subsidies have not helped to increase the productive capacity of famers.

H1: The government subsidies have helped to increase the productive capacity of famers.

Out 500 respondents, 97 respondents disagree that Government Subsidies have helped to increase the productive capacity of famers & 403 respondents agree that Government Subsidies have helped to increase the productive capacity of famers.

Table No. 2 - Two-Sample T-Test (MINITAB Code):

Code	N	Mean	St. Dev	SE Mean
No	15	6.47	1.92	0.50
Yes	15	26.87	1.73	0.45

Source- Minitab Software

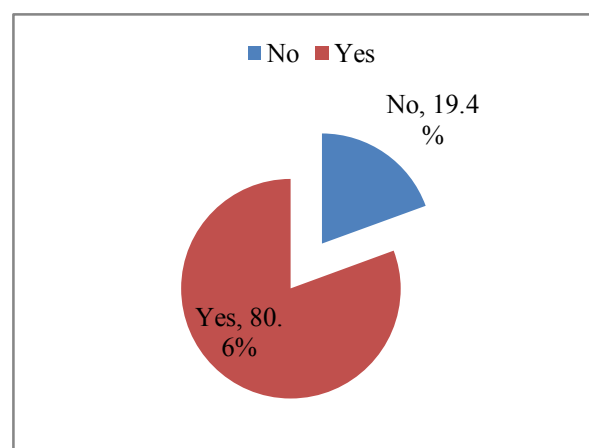

Figure No.3- Government subsidies have helped to increase the productive capacity

In above table mean value of code Yes is 26.87, standard deviation is 1.73 & SE mean is 0.45. And mean value of code No is 6.47, standard deviation is 1.92 & SE mean is 0.50.

Result

Difference = μ (No) - μ (Yes)
Estimate for difference: -20.400
95% CI for difference: (-21.767, -19.033)
T-Test of difference = 0 (vs \neq): T-Value = -30.58
P-Value = 0.000 DF = 28
Both use Pooled StDev = 1.8270

The estimate for the difference is -20.400, T-Value = -30.58, P-Value = 0.000, DF = 28 And Standard Deviation is 1.8270. Since P-Value is less than 0.05 (L.O.S.), the hypothesis is accepted by the researcher. The government subsidies have helped to increase the productive capacity of farmers.

Conclusion

The author concludes that development of agriculture sector possible in India. The major part of agriculture subsidy in India is provided through indirect form to agriculture sector. The farmers in the Jalgaon District are receiving subsidy from bank, fertilizer company & electricity board. The agricultural production of Jalgaon District is continuously increases and most of the farmers in Jalgaon District received subsidy from more than nine years. It means that subsidy has helpful for agricultural growth of Jalgaon District. The subsidies make a positive impact on the agricultural sector of Jalgaon District. The subsidy helps farmers for reducing his cost of production. Agricultural subsidies are helpful for the growth of agricultural sector in Jalgaon District.

References

1. Agricultural policy. (2001, 1 15). Retrieved 6 10, 2012, from http://en.wikipedia.org/http://en.wikipedia.org/wiki/Agricultural_policy
2. Farmer's Access To Agricultural Credit. (2005, 11 1). Retrieved 8 2, 2012, from <http://agricoop.nic.in/http://agricoop.nic.in/imagedefault/credit/Agriculture-Credit-Overview.pdf>
3. Murdeshwar, V. (2013, 9 23). Indian Express. Retrieved 5 2, 2014, from <http://www.newindianexpress.com/http://www.newindianexpress.com/states/karnataka/90-percent-subsidy-for-drip-irrigation-CM/2013/09/23/article1798818.ece>
4. Cooperation, D. o. (n.d.). Micro Irrigation Guideline . Retrieved 5 10, 2014, from http://agricoop.nic.in/http://agricoop.nic.in/horticulture/micro_guidelines.htm
5. Handbook. (2012, 7). Farmer Friendly Handbook for government schemes and programmes . Pune, Maharashtra, India: Commissionerate of Agricultural , Agricultural Department of Maharashtra
6. The effects of subsidies. (n.d.). Retrieved 8 27, 2013, from Global subsidies Initiative : <http://www.iisd.org/gsi/effects-subsidies>
7. Department of Agriculture, Government of Maharashtra. (n.d.). Retrieved 5 10, 2014, from <http://www.mahaagri.gov.in/http://mahaagri.gov.in/level3detaildisp.aspx?id=6&subid=11&sub2id=1>
8. E-Jalgaon . (n.d.). Retrieved 8 12, 2013, from <http://ejalgaon.com/jalgaoninfo/jalgaonDistrictprofile.htm>
9. Maharashtra, G. o. (n.d.). <https://cultural.maharashtra.gov.in>. Retrieved 8 5, 2013, from https://cultural.maharashtra.gov.in/english/gazetteer/JALGAON/his_early.html
10. Dr. Harshal Anil Salunkhe (2016, Sep 16). Ph.D Thesis. A Study of Impact of Government Subsidy on Agriculture Sector in Jalgaon District . Jalgaon, Maharashtra, India.
11. Harshal Anil Salunkhe, Dr. B. B. Deshmukh, H. A. (2014). The Sustainable Development of Agriculture Sector through Subsidies is Possible in Ind. International journal of Commerce, Management & Economics ZIJBEMR , 97-103.
12. Harshal Anil Salunkhe, Dr. B.B. Deshmukh, H. A. (2012). Overview of government subsidies to agriculture sector in India. IOSR Journal of Agriculture and Veterinary Science , 43-47.
13. H. A. Salunkhe, (2016). Bureaucracy: A Study of Distribution Process of Agriculture Subsidy in India. International Journal Engineering Trends and Technology , 5-8.
14. Harshal Anil Salunkhe. (2015). The Study of Corporate Governance and Legal Issue in Agriculture Sector in India. Emerging Issues in Legal Aspects of Business. Jalgaon: Atharv Publication, Jalgaon.

Algorithms for Energy Efficient Routing of Mobile & Wireless Sensor Networks

Reena Nibandhe, Dr.K.Krishna Naik
Defence Institute of Advanced Technology, Pune

ABSTRACT:

Mobile & Wireless Sensor Network's prime aim is to gather information from different sensor nodes wirelessly and mobile. Mobile & Wireless sensor networks are energy constraint due to battery operating sensors. Energy optimisation is an important factor to increase the lifetime of the network. They take power for sensing, computation & communication. They collect the information from where they deployed

and then transfer its to sinks. To forward the information in the network routing protocols plays vital role with its nature and application. This paper concentrates study of various algorithms available and applicable to MWSN, which achieves efficient energy optimisation with different approaches of algorithms.

Keywords- Routing, Mobile Nodes, Routing Protocols, Clustering, Wireless Sensors

I. INTRODUCTION

Recent advances in communication, each field like computing, communication, mobility and energy efficiency are the major needs towards development of mobile and wireless communication network. These networks are useful in efficient surveillance, environmental monitoring and industrial automation. This network is to be a part of static and part of dynamic configuration of the topology. It is very difficult to configure in both topologies as the nodes belongs to the network maybe stationary or

mobile. This problem again leads towards quality of service of the network. To overcome this problem the topology has to be formulated using the methods proposed based on the possible mobility and energy constraints. Energy is a limiting factor in case of MWSN; first-Energy of nodes is crucial and depends upon battery which has limited power supply, second-Nodes can move in an uncontrolled manner so frequent route failures are possible and third-

Wireless channels have lower and more variable bandwidth compare to wired network.

In the network during the transactions of its nature and sensing, faster energy will be depleted from the node in action, hence there are chances of malfunctioning or failure of route. It affects the network connectivity and coverage. To overcome this problem, an efficient algorithm need to be placed for replacing that nodes but it's not practically possible in case of remote location or hazards environment. Second approach to this problem is used multiple sink nodes or mobile sink nodes. To realise the goal of large scale MWSN nodes, there are basically two modes of operations of MWSN i.e. locally sensing and remote sensing [1][7].

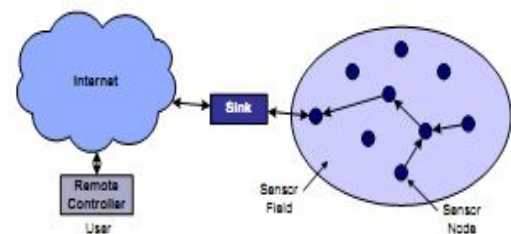

Figure 1: A generic model of MWSN

Energy dissipation model:

The link energy consumption rate due to transmissions between node i and node j can be modelled as

$$E_t(i, j) = \alpha \cdot f_{i,j} \quad (1)$$

$$E_r(j, i) = \beta \cdot f_{i,j} \quad (2)$$

where $E_t(i, j)$ denotes the energy consumed at node i when transmitting to node j with bit rate $f_{i,j}$, $E_r(j, i)$ denotes the energy consumed at node j when receiving from node i with bit rate $f_{i,j}$. While $d_{i,j}$ is denoting the bit transmission distance and d_{max} is the transmission range, the parameter α for sending cost is typically defined as:

$$\alpha = \begin{cases} a + b \cdot d_{i,j}^{\gamma} & \text{when } d_{min} \leq d_{i,j} \leq d_{max} \\ a + b & \text{when } 0 \leq d_{i,j} \leq d_{min} \end{cases} \quad (3)$$

Where $\gamma = 2$ is the decay factor, $a = 50\text{nJ/bit}$, and $b = 100\text{pJ/bit/m}^2$. The parameter β for receiving cost typically has the same value as a , i.e. $\beta = 50\text{nJ/bit}$. Note that the parameter d_{min} is the threshold under which there is no evident signal attenuation.

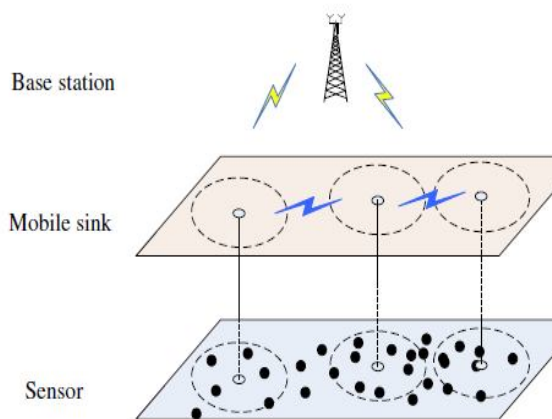

Figure 2: Basic adaptable architecture of WSN for energy efficiency

This paper discusses various algorithms can be used for these networks along with the taxonomy proposed.

II. INTER & INTREA CLUSTER ROUTING ALGORITHMS

In this algorithm, the sensor nodes in the MWSN organize themselves into local clusters, with one node acting as the local base station or cluster-head. The functions of cluster-head include not only the general functions, such as data acquisition and forwarding, but also the local data fusion to “compress” the amount of data being sent from the clusters to the base station, further reducing energy dissipation and enhancing system lifetime [2]. The process of forwarding packets between the source nodes in the target region and the base station consists of two phases i. e. (1) Inter-cluster routing (The cluster-head of the target region communicates with the base station directly or only through other cluster-heads) and (2) Intra-cluster routing (the source nodes in the target cluster communicate with its cluster-head directly or only through other source nodes).

In Inter cluster algorithm, on picking a next hop, a cluster-head makes reference to the cost of its neighbour cluster-head to the destination, that is, a cluster-head tends to choose its neighbour cluster-head with lower cost to the destination as the next-hop node. In Intra cluster routing algorithm, when a query packet reaches the target cluster, the cluster-head firstly receives the packet, and then a forwarding strategy similar to GEAR protocol is adopted. A simple flooding can be used to flood the packet inside the cluster when the number of intra-cluster nodes is less than a predetermined threshold, otherwise the recursive geographic forwarding approach would be used to disseminate the packet inside target cluster, i.e. the cluster-head divides the target cluster into some sub-regions, creates the same number of new copies of the query packet, and then disseminates these copies to the node in a central position of each sub region. Repeat this recursive splitting and forwarding procedure until no nodes in current sub-region or reaching the maximum transmission hop-count.

ENERGY-EFFICIENT DYNAMIC OUTING TREE

A query-based routing tree is called energy-efficient dynamic routing tree (EDRT), that is separately constructed for each query by utilizing the query information. The main objective of the EDRT is to minimize the number of hops by increasing the amount of data merge processing, thus reducing the total number of generated messages to reach the destination. The EDRT is constructed in such a way that messages generated from sensor nodes can be merged more often and earlier [6].

This algorithm consists of two stages. Candidate Set Decision Stage: This stage determines the parent candidate set and sibling candidate set for each node. Query Dissemination and EDRT Construction Stage: When a user requests a query, the EDRT for the query is constructed through the query dissemination. Each sensor node calculates the md (minimum distance) value and sends the query message with this value to neighbour nodes which has the smallest md (minimum distance) value.

III. ENERGY-EFFICIENT ANT BASED ROUTING ALGORITHM

Energy aware Ant-based Dynamic Hop Optimization Protocol (ADHOP) is a self-configuring and multihop reactive routing protocol which aims at providing a low-overhead routing for mobile WSNs. It uses the ant collective behaviour to make routing decisions by pheromone and heuristic information[3][4]. ADHOP can adapt to network changes, such as mobility and node failures. In fact, ADHOP is designed to use one or more heuristic information to support routing decisions according to the network needs, such as distance, latency, residual energy, and/or Received Signal Strength Indicator (RSSI). Our approach aims at using residual energy information to distribute the network traffic load, thus reducing the energy consumption per delivered data.

To implement these ideas, the memory M_k of each ant is reduced to just two records, the last two visited nodes. Since the path followed by the ants is no more in their memories, a memory must be created at each node that keeps record of each ant that was received and sent. Each memory record saves the previous node, the forward node, the ant identification and a timeout value. Whenever a forward ant is received, the node looks into its memory and searches the ant identification for a possible loop. If no record is found, the node saves the required information, restarts a timer, and forwards the ant to the next node. If a record containing the ant identification is found, the ant is eliminated. When a node receives a backward ant, it searches its memory to find the next node to where the ant must be sent. The timer is used to delete the record that identifies the backward ant, if for any reason the ant does not reach that node within the time defined by the timer.

The vector E_k was erased from the forward ants k , that now only carry the average energy till the current node (E_{Avgk}), and the minimum energy level registered (E_{Mink}). These values are updated by each node that receives the forward ants. When the forward ant reaches the sink-node these values are used to calculate the amount of pheromone trail used by the corresponding backward ant:

$$\Delta T_k = \frac{1}{C - \left[\frac{E_{Min_k} - Fd_k}{E_{Avg_k} - Fd_k} \right]} \quad (4)$$

Calculating ΔT_k only as a function of the energy levels of the path can bring no optimized routes, since a path with 15 nodes can have the same energy average as a path with only 5 nodes. Therefore ΔT_k must be calculated as a function of both parameters: the energy levels and the length of the path. This can be achieved by introducing the parameter Fd_k in the equation, which represents the number of nodes that the forward ant k has visited.

IV. HETEROGENEOUS SENSOR NETWORK MODEL

Heterogeneous sensor network (HSN) modelled by both Low (L) as well as High (H) Energy sensors and are distributed uniformly and randomly in the environment. The sensor H form cluster and around them act as cluster heads. The cluster formation is depicted in figure 4, consists of L sensors, H sensors and the Base station (BS). H sensors provide longer transmission range, higher data rate than L sensors and also facilitates better protocols, algorithms, and secure schemes in sensor networks. As an efficient and robust cluster formation scheme is adopted in HSN the sensor nodes provide coverage of the region with a high probability. Cluster heads are responsible for data aggregation and transmission of the aggregated data to a base station[10].

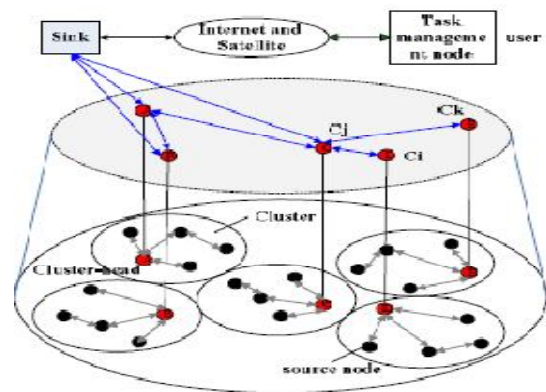

Figure 3: Different types of clustering

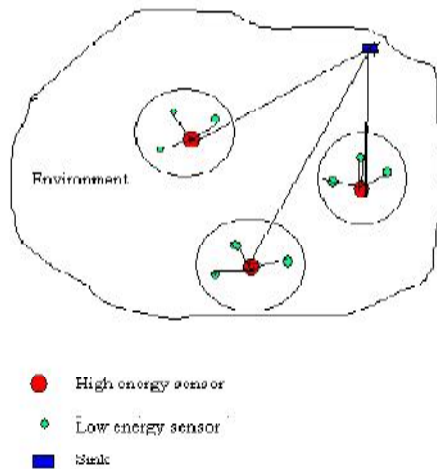

Figure 4: Heterogeneous sensor model

IV. CONCLUSIONS

Algorithms discussed in this paper are highly adaptable for the Mobile & Wireless sensor networks. All the algorithms follow the discussed energy dissipation model applicable for wireless sensor networks similarly for mobile networks also. The inter & intra cluster routing algorithm makes the division of the local and nonlocal nodes of the cluster in the name of stationary and mobile node. This algorithm is specially focuses on the mobility of the nodes between clusters. The energy-efficient dynamic routing tree algorithm also helps the MWSN as per the mobility nature of the nodes of the MWSN. The dynamic configuration of this algorithm is highly recommendable for the nodes in mobility in nature. The energy-efficient ant based routing algorithm also useful as it will be with energy aware ant-based dynamic hop optimization protocol and having a property of self-configuring and multihop reactive. Ant collective behaviour of this algorithm makes routing decisions by pheromone and heuristic information can adapt to network changes, such as mobility and node failures. The final heterogeneous sensor network

model algorithm helps MWSN in taking care of different energy levels and clusters types.

REFERENCES

- [1] Ajit Singh et al. "A Survey of Energy Efficient Routing Protocols for Mobile Ad-hoc Networks" (IJCSSE) International Journal on Computer Science and Engineering Vol. 02, No. 09, 2010, 3111-3119.
- [2] Guisheng Yin, Guang Yang, Wu Yang, Bingyang Zhang, Wenjin Jin "An Energy-Efficient Routing Algorithm for Wireless Sensor Networks" 2008 International Conference on Internet Computing in Science and Engineering, 182-185.
- [3] Tiago Camilo, Carlos Carreto, Jorge Sá Silva, Fernando Boavida "An Energy-Efficient Ant-Based Routing Algorithm for Wireless Sensor Networks", A project Report
- [4] Nidhi Batra, Anuj Jain, Surender Dhiman "An Optimized Energy Efficient Routing Algorithm For Wireless Sensor Network" international journal of innovative technology & creative engineering (issn:2045-8711) vol.1 no.5 may 2011
- [5] Alexandre Massayuki Okazaki and Antônio Augusto Fröhlich "ADHOP: an Energy Aware Routing Algorithm for Mobile Wireless Sensor Networks" A Paper downloaded from Internet.
- [6] Si Gwan Kim, Hyong Soon Park "Energy-Efficient Dynamic Query Routing Tree Algorithm for Wireless Sensor Networks" (IJACSA) International Journal of Advanced Computer Science and Applications, Vol. 3, No.2, 2012, 123-129.
- [7] Canfeng Chen, Jian Ma, Ke Yu "Designing Energy-Efficient Wireless Sensor Networks with Mobile Sinks" WSW'06 at Sensys'06, October 31, 2006.
- [8] Tijs van Dam, Koen Langendoen "An Adaptive Energy Efficient MAC Protocol for Wireless Sensor Networks" SenSys'03, November 5-7, 2003, Los Angeles, California, USA.
- [9] S.V. Manisekaran, R. Venkatesa, G. Deivanai "Mobile Adaptive Distributed Clustering Algorithm for Wireless Sensor Networks" International Journal of Computer Applications (0975 - 8887) Volume 20- No.7, April 2011 12-19
- [10] Sudarmani R. K. R. Shankar Kumar "Energy-Efficient Clustering Algorithm for Heterogeneous Sensor Networks with Mobile Sink" European Journal of Scientific Research ISSN 1450-216X Vol.68 No.1 (2012), pp. 60-71

Characterization of Voltage Sag due to Faults and Induction Motor Starting

P. R. Bharambe & S. S. Jadhao

Département of Electrical Engineering, S.S.G.M. Collège of Engineering, Shegaon, (MS) India
pr_bharambe@rediffmail.com, ssjadhao@gmail.com

ABSTRACT:

This paper focus on events, that causes a temporary decrease in the magnitude of voltage at power frequency. The paper aims at characterization of voltage sags due to faults and induction motor starting. The modified IEEE distribution system is considered for study and same is simulated using PSCAD. The signals for features extraction are processed using Wavelet transform. The Statistical parameters computed from detailed level 4 (D-4) are used as an input to classifier. Multilayer perceptron network is used as a classifier to differentiate the cause behind the voltage sag.

Index Terms- power quality, Voltage sag, power system faults, wavelet transform, MLP

I. INTRODUCTION

For the satisfactory operation of end use devices, the utility is expected to supply undistorted, sinusoidal rated voltage continuously at rated frequency to the end users. A power quality problem can be defined as “any problem manifested in voltage, current, or frequency deviations that results in failure or mal-operation of end user equipment”. Over the last decade voltage sag gains a serious concern amongst the utility, end users, equipment manufacturers as well as researchers. Voltage sag is a power quality problem that is prevalent in any power system. Voltage sag have attracted a lot of attention due to the problems that causes failure to equipment like adjustable speed drives, computers, industrial control systems etc.

The main causes of voltage sag are due to faults and large rating induction motor starting. Modern power electronic devices or equipments are sensitive to voltage variations and susceptible to damage. This increased sensitivity of the equipments to voltage sag has highlighted the importance of quality of power.

Ozgur Gencer et al. [1], a new voltage sag detection method based on wavelet transform is developed. This paper presents a practically efficient method for the voltage sag detection. The method uses discrete wavelet transforms to determine beginning and ending of the voltage sag with sag magnitude. WT are essentially applied to extract information and as a basis for signal representation to achieve both good time and frequency position. The discrete wavelet transform (DWT) is used to detect fast changes in the voltage signals, which allows time localization of differences frequency components of a signal with different frequency wavelets. The DWT provides sufficient information both for analysis and synthesis of the original signal, with a significant reduction in the computation time.

In Tulasi Ram, et al. [2], described a wavelet transform is proposed to identify the power quality disturbance at its instance of occurrence. Power quality disturbances like sag, swell, interruption, DC offset, frequency variation and harmonics are considered and are decomposed up to 4 levels using Db4 wavelet. For some disturbances it is sufficient to have only second or third level of decomposition. The exact location of the disturbance can also be found on the time scale.

In paper Memon, et al. [3], described detection of PQ disturbances must be carried out first. PQ disturbances have been defined into several categories and software based novel approach techniques for detection of PQ disturbances by time and frequency analysis with wavelet transform is proposed. These techniques detect PQ problems of waveform distortion and provide a promising tool in the field of electrical power quality problems.

Santoso. S, et al. [4], presents a new approach to detect, localize, and investigate the feasibility of classifying various types of power quality disturbances. It is based on wavelet transform analysis, particularly the dyadic-orthonormal wavelet transform. The key idea underlying the approach is to decompose a given

disturbance signal into other signals which represent a smoothed version and a detailed version of the original signal. The decomposition is performed using Multiresolution signal decomposition techniques. It demonstrates and tests their proposed technique to detect and localize disturbances with actual power line disturbances. Base on the results of the detection and localization, they carry out an initial investigation of the ability to uniquely characterize various types of power quality disturbances.

Julio Barros et al. [5] presents an extensive literature review of the application of wavelet transforms in the detection and analysis of voltage events and provides a short description of the different methods proposed. The use of wavelets provides simultaneous time-frequency information of a signal, which is of special interest in the processing of voltage events. Applying wavelet transforms, high time resolution is provided for high-frequency components and low time resolution is obtained for low-frequency components of the signal.

Paper [6] deals with the use of wavelet analysis and neural systems as a new tool for the analysis of power system disturbances, disturbances are automatically detected, compacted, and classified. In this work, a WT approach is proposed to detect and classify various types of power systems disturbances. A neural classification system using wavelet analysis has been used to distinguish Power system disturbances. This work leads us to believe that wavelet analysis together with neural structure, as a new tool, offers a great potential for diagnosis of electrical power systems in the area of power quality problems.

S. suja et al.[7] discussed the power signal disturbances are detected using discrete wavelet transform (DWT) and categorized using neural networks. DWT is employed to capture the time of transient occurrence and extract frequency features of power disturbances. The coefficients obtained from DWT are further subjected to statistical manipulations for increasing the detection accuracy. PNN is used to classify disturbance type. The wavelet neural classifier along with the statistical computation has increased the classification accuracy

Paper [8], deals with the use of a continuous wavelet transforms to detect and analyze voltage sags and transients. A recursive algorithm is used and improved to compute the time-frequency plane of these electrical disturbances. Characteristics of investigated signals are

measured on a time-frequency plane. A comparison between measured characteristics and benchmark values detects the presence of disturbances in analyzed signals and characterizes the type of disturbances. Duration and magnitude of voltage sags are measured.

I. SYSTEM UNDER STUDY

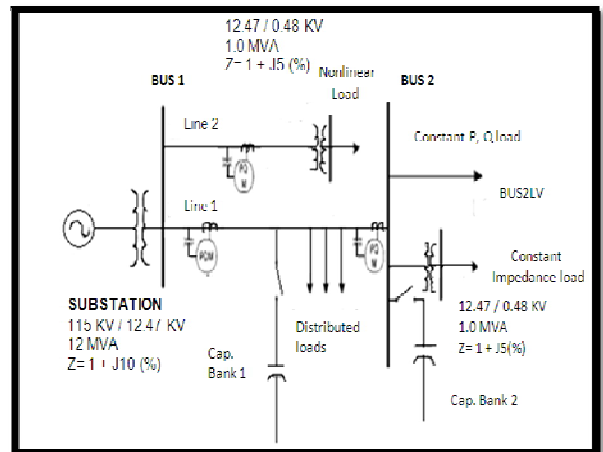

Fig.1: The modified IEEE distribution test feeder.

The details of the system under study are as follows:

Busses:

Bus 1: 12.47 kV, Bus 2: 12.47 kV,
Bus 3: 0.48 kV, Bus 4: 0.48 kV

Transmission Lines TLine1, TLine2:

Steady state frequency: 50Hz
Length: 5 Km
Number of conductors: 3

Transformers:

T1: Three phase, star/star, 50Hz, 12MVA,
115 kV/12.47 kV.
T2, T3: Three phase, star/star, 50Hz,
1.0MVA,
12.47kV/0.48kV

Induction motor:

Wound rotor induction motor
Rated power = 1.615 [MW]
Rated voltage [L-L] = 12.47 [kV]

Load at:

Bus 2: 0.30 MW, 0.15 MVAR, and 12.47 kV
Bus 3: 0.15 MW, 0.05 MVAR, and 0.48 kV
Bus 4: 0.10 MW, 0.05 MVAR, and 0.48 kV

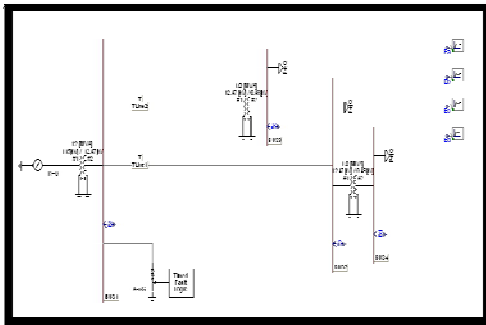

Fig.2: Simulation faults in PSCAD

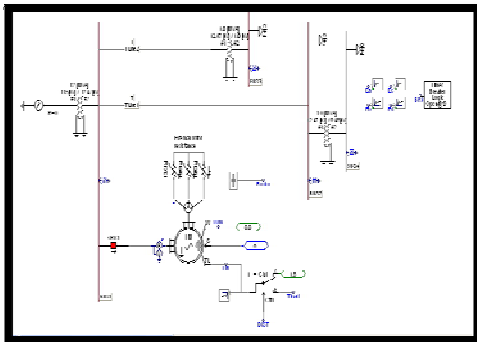

Fig.3 Simulation of Induction Motor Starting in PSCAD

Figure 2 and 3 shows a single line diagram of the system simulated in PSCAD for LG faults and induction motor starting. The study is carried out on BUS1 of the sample test system.

III WAVELET TRANSFORM

The wavelet transform represents signal as a sum of wavelets at different locations (positions) and scales (duration). The wavelet coefficients work as weights of the wavelets to represent the signal at these locations and scales.

The Discrete Wavelet Transform:

The Discrete Wavelet (DWT), is used to decompose a discretized signal into different resolution levels. It maps a sequence of numbers into a different sequence of numbers.

The discrete wavelet transform DWT provides sufficient information both for analysis and the synthesis of the original signal, with a significant reduction in the computation time. The DWT provides a time and frequency representation of the recorded power quality signals. This is a very attractive feature in analyzing time series because time localization of spectral components can be obtained. Classical

methods of signal processing depend on an underlying notion of stationary, for which methods such as Fourier analysis are very well adapted. In power quality researches, however, more properties other than stationary are required, and thus make the DWT application more appropriate than Fourier transform.

Wavelet Families:

There are a number of basis functions that can be used as the mother wavelet for Wavelet Transformation. Since the mother wavelet produces all wavelet functions used in the transformation through translation and scaling, it determines the characteristics of the resulting Wavelet Transform.

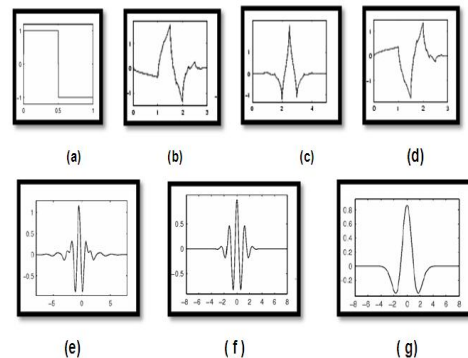

Fig 4 : Wavelet families (a) Haar (b) Daubechies4 (c) Coiflet1

(d) Symlet2 (e) Meyer (f) Morlet (g) Mexican Hat.

Fig 4: illustrates some of the commonly used wavelet functions. Haar wavelet is one of the oldest and simplest wavelet. Daubechies wavelets are the most popular wavelets. They represent the foundations of wavelet signal processing and are used in numerous applications. The Haar, Daubechies, Symlets and Coiflets are compactly supported orthogonal wavelet. The wavelets are chosen based on their shape and their ability to analyze the signal in a particular application. These wavelets along with Meyer wavelets are capable of perfect reconstruction. This paper uses Daubechies-4(db4) method for feature extraction.

IV. MULTILAYER PERCEPTRON

MLP is a powerful system, often capable of modeling complex, relationships between variables. It allows prediction of an output object for a given input object. The

architecture of MLP is a layered feed forward neural network in which the non-linear elements (neurons) are arranged in successive layers, and the information flow is unidirectional from input layer to output layer through hidden layers. An MLP with just one hidden layer can learn to approximate virtually any function to any degree of accuracy. For this reason MLPs are known as universal approximates and can be used when there is little prior knowledge of the relationship between input and targets. One hidden layer is always sufficient provided enough data is present.

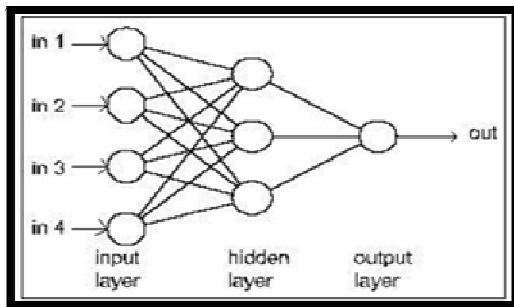

Fig. 5 Architecture of ANN

V STATISTICAL PARAMETERS

The statistical parameters used in the study are discussed as follows.

Maximum value: The maximum value attained by a signal i.e. it refers to maximum signal point value of given sample.

Standard deviation: Standard deviation is the square root of the arithmetic average of the squares of the deviations measured from the mean i.e. it is a measure of the dispersion of a set of data from its mean. The more spread apart the data, the higher the deviation.

The standard deviation is calculated as

$$\sigma = \sqrt{\frac{1}{N} \sum_{i=1}^n (x_i - \mu)^2}$$

Where, μ is the mean of x , σ is the standard deviation of x

Mean value (μ) is calculated as

$$\mu = \frac{1}{N} \sum_{i=1}^n x_i$$

Energy: The energy of the signal is calculated as

$$E_x = \sum_{n=-\infty}^{\infty} |X(n)|^2$$

VI RESULTS AND DISCUSSION

Time Domain Approach:

[1] Voltage sags due to faults

The voltage sags is observed in the system voltage due to the creation of different faults like LG, LLG, LLLG. The faults are created in the circuit by using timed fault logic for specifying the instant of fault and the duration. The study has been conducted on BUS1. At BUS1 voltmeter E_a is connected for measuring the bus voltage. It has been observed that the voltage sag occurs between the times a fault initiates. The voltage sag remains till recovery of fault. After recovery of fault, normal value of voltage is obtained. The other buses i.e. BUS1, BUS2, BUS3, BUS4 are also affected.

[A] LG fault

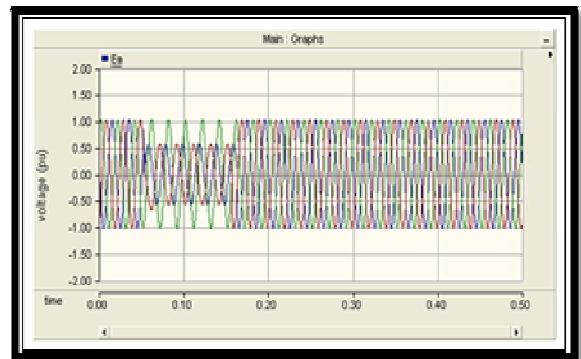

Fig.6 (a): Voltage sag due to LG fault

In this case fault is created in phase c to ground. It has been observed there is sag in only one phase i.e. (in phase c).

[B] LLG fault

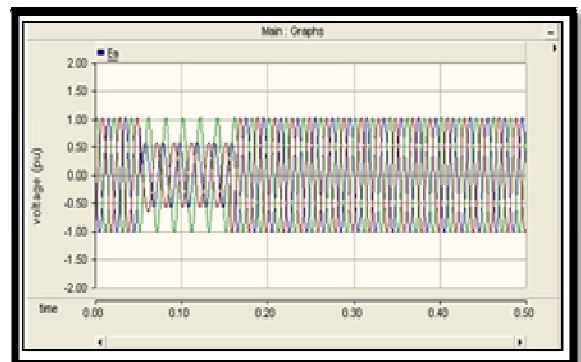

Fig.6 (b): Voltage sag due to LLG fault

In this case fault is created in phase A and C along with the ground. From fig.6(b), it has been observed there is sag in two phase and magnitude of voltage magnitude is reduced i.e. voltage sag is obtained.

[C] LLLG fault

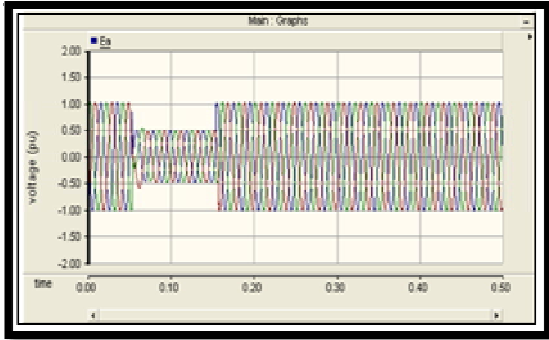

Fig.6 (c): Voltage sag due to LLLG fault

Voltage sag due to LLLG fault as shown in fig. 6(c). It has been observed there is sag in three phases A, B and C along with the ground. The magnitude of voltage is reduced i.e. voltage sag obtained.

[2] Voltage sags due to induction motor starting

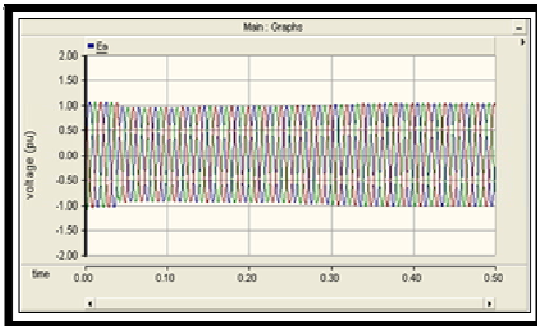

Fig.6 (d): Voltages sag due to induction motor starting

The voltage magnitude is reduced i.e. voltage sag is obtained. This voltage sag is symmetrical: all three phases drop equally and then recover gradually in a similar way because the starting current of the motor is the same for all three phases.

Wavelet Transform for Feature Extraction:

The signals obtained from PSCAD are further analyzed using wavelet transform. The wavelet transform decomposed the signal up to six decomposition levels using db4 wavelet. The

decomposition gives approximations and detailed coefficients.

The decomposed signal for voltage sags due to different faults like LG, LLG, LLLG and induction motor starting are as shown below.

[1] Wavelet decomposition of signal for voltage sags due to faults

[A] LG fault

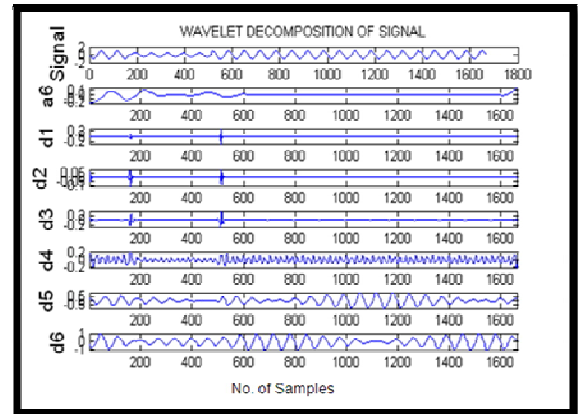

Fig.7 (a): Wavelet decomposition of signal of voltage sag due to LG fault

Fig.7 (a) shows the original signal and wavelet decomposition of waveforms of voltage signal up to sixth level of LG fault i.e. (phase c to ground fault). The original signal shows the voltage sag due to LG fault. The effect of LG fault can be more clearly visualized in D4 level.

[B] LLG fault

Fig.7 (b) shows the original signal and wavelet decomposition of waveforms of voltage signal up to sixth level of LLG fault. Here fault involves phase A and phase C along with the ground.

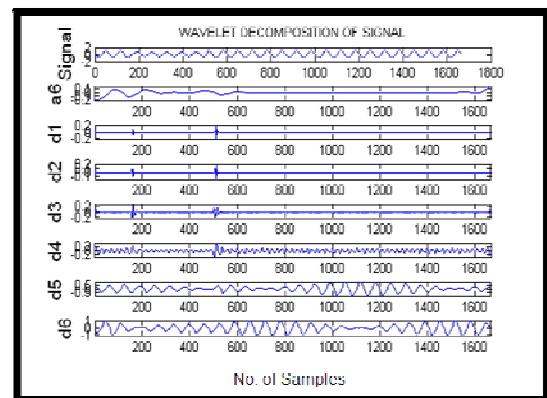

Fig. 7(b): Wavelet decomposition of signal of voltage sag due to faults

[C] LLLG fault

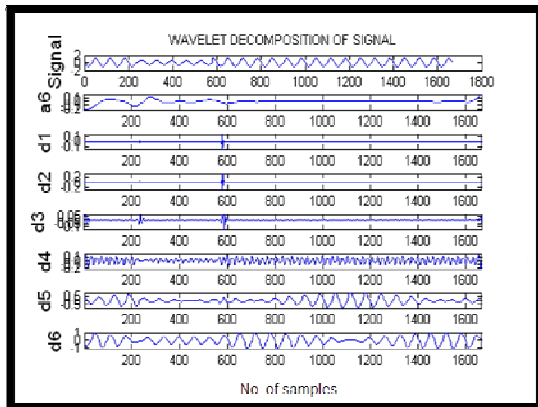

Fig.7 (c): Voltage sag due to LLLG fault

Fig.7(c) shows the original signal and wavelet decomposition of waveforms of voltage signal up to sixth level of LLLG fault. Here fault involves all the three phases A, B and C along with the ground. The original signal shows the voltage sag due to LLLG fault. The effect of LLLG fault can be more clearly visualized in D4 level.

[2] Wavelet decomposition of signal of Voltage sag due to starting of induction motor

The wavelet decomposition of waveforms of voltage signal up to sixth level using Db4 wavelet of induction motor starting is shown in fig.7(d). From wavelet transform approach, classification of voltage sag due to faults and induction motor starting are not possible by visual inspection. Because of this drawback various statistical parameters such as maximum value, standard deviation, variance, skewness, kurtosis and energy are calculated.

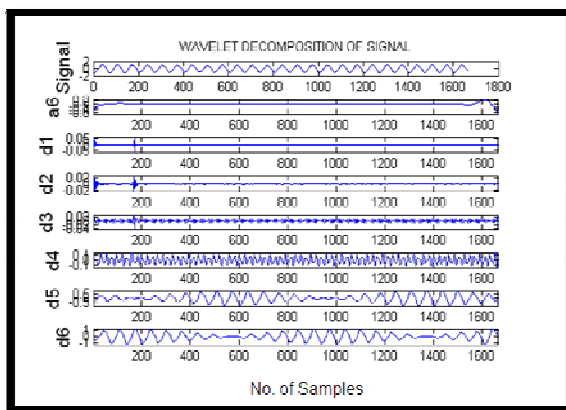

Fig.7 (d): Wavelet decomposition of signal of voltage sag due to induction motor starting.

Statistical Parameters Approach:

The detailed coefficient at level 4 obtained from DWT is further subjected to various statistical parameters for increasing the detection accuracy. The statistical parameter such as maximum value, std. deviation and energy are computed. Fig.8(a)-8(c) shows the graphs of various statistical parameters for voltage sags due to different faults like LG, LLG, LLLG and induction motor starting of detailed coefficient at level 4.

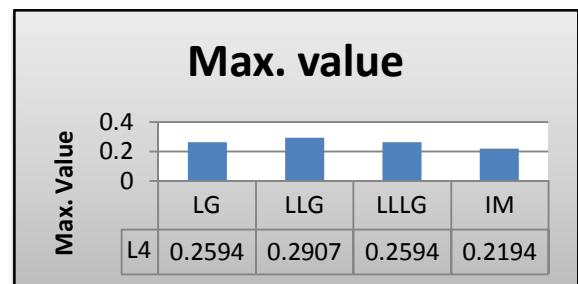

Fig.8 (a): Maximum value of detailed coefficient at level 4

It has been observed that the magnitude for LG and LLLG fault is near about same.

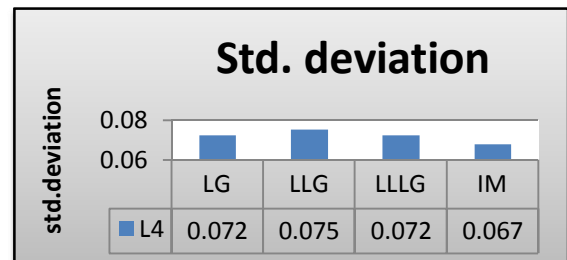

Fig.8 (b): Standard deviation of detailed coefficient at level 4

From fig.8 (b), it has been observed that the magnitude of LG and LLLG fault is same.

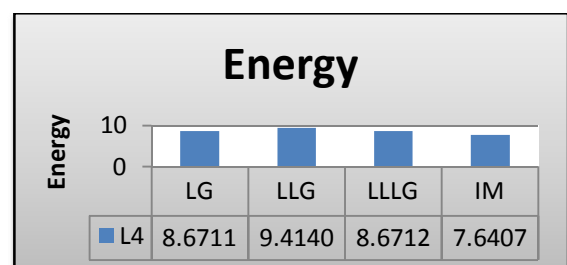

Fig.8(c): Energy of detailed coefficient at level 4 for voltage

It has been observed that the magnitude of LG and LLLG fault is near about same.

From six different statistical parameters such as maximum value, standard deviation, variance,

skewness, kurtosis and energy. It is clear that with the help of visual inspection of various statistical parameters of voltage sags due to different faults and induction motor starting is not an easy task to classify properly.

Result Obtained from ANN

When energy parameter is given as input to Multilayer perceptron network.

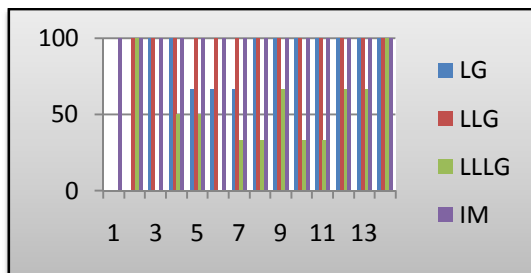

Fig.9: Effect of number of processing element on classification accuracy for energy parameters by using MLP

The fig.9 indicates that when number of processing element is taken as 14, then 100% accuracy is obtained. The voltage sag classification is performed for different faults like LG, LLG, LLLG and induction motor starting.

Hence, the classification of voltage sags due to faults and induction motor starting is done by using ANN technique from which there is 100% accuracy.

CONCLUSION

The modified IEEE distribution test feeder System is simulated in PSCAD. The data obtained from simulation is in time domain. With the help of magnitude of voltage and duration of events, the cause of voltage sags cannot discriminate properly. Hence in order to obtain correct classification the Wavelet - ANN approach is used.

MLP for energy parameter gives 100% results i.e. 100% classification of voltage sags due to various types of faults and induction motor starting.

REFERENCES

[1] Ozgur Gencer, Semra Ozturk, Tarik Erfidan, "A new approach to voltage sag detection based on

wavelet transform", Electrical power and Energy system.
Dr.G. Tulasi Ram, Dr. M Sushama, Dr. A Jaya Laxmi, "Detection of Power Quality Disturbances Using Wavelet Transforms" International Journal of Computer, Vol. 18.No.1, April 2010, pp 61-66.
Memon. A.P, T.R Mohamad, Z. A. Memon, "Detection of power Quality Disturbance using wavelet Transform Techniques" International Journal for the advancement of science and Arts, Vol.1, Jan 2010
Santoso. S, E J Powers, Peter Hofmann, "Power quality assessment via wavelet transform analysis," IEEE Transaction, vol. 11, Apr. 1996, pp. 924-930.
Julio Barros*, Ramón I. Diego, Matilde de Apráiz, Applications of wavelets in electric power quality: Voltage events, Electric Power Systems Research.
Dolores Borrás, M. Castilla, Member, IEEE, Narciso Moreno, and J. C. Montaña, Senior Member, IEEE, "Wavelet and Neural Structure: A New Tool for Diagnostic of power system Disturbances" IEEE Transaction on industry application Vol.37, No.1, January/February 2001
S. Suja, Jovitha Jerome, " Power Signal Disturbance Classification Using Wavelet Based Neural Network", Serbian Journal of Electrical Engineering, Vol. 4, No. 1, June 2007, pp. 71-83
Olivier Poisson, Pascal Rioual, and Michel Meunier "Detection and Measurement of Power Quality Disturbances Using Wavelet Transform" IEEE Transaction on Power Delivery, Vol.15, No.3, JULY 2000

Man is the Universe

Pujyasri Bhikshamaiah Guruji

Sri Sathya Sai Dhyaanamandali

VIJAYAWADA- 520 002.

www.srisatyasaidhyanamandali.org

The finest art which is most difficult to learn is the art of living. Those who lead artistic life, can properly utilize their life purposefully. While others misuse it. Man is potentially divine and a special creation of God. Because he is supreme creation on this planet Earth. There is no boundary for the power of human mind. Human mind is the infinite library of the universe. No knowledge comes from outside... everything is within it. Nothing is impossible to the human mind. An average man has a brain capacity of about 1500 cc and has approximately 13 billion nerve cells. It is understood that even a great scientist can utilize his brain capacity up to 20 per cent only, others are always mild and sleepy. Those who utilize their strength in toto can create wonders in this world. This is only possible for a Spiritualist. Others can't utilize them totally. Because of strong materialism due to intense competition, now a days the man suffers from stress and strain which has become a common factor prevalent among the human race. Most of the people are prone to unbearable mental tensions which lead to cause incurable chronic diseases. To get rid of those dangerous ailments - - physical and psychological, both the Yoga and the Meditation have become the need of the hour and essential to lead peaceful life. Both of them play significant and vital role in Spirituality. With the result, peace and harmony develop in social environment. Spirituality is nothing but Scientific self - knowledge. It is the mother of all other sciences. All sciences are branches of the Spiritual science. If anybody knows about the Spirituality in a scientific manner, he does not need to know anything more. Spirituality is purely meant for...

- 1) Self - Study
- 2) Self - Analysis
- 3) Self - Purification
- 4) Self - Awareness

- 5) Self - Control
- 6) Self - Criticism
- 7) Self – Introspection
- 8) Self - Research
- 9) Self - Reformation
- 10) Self –Realisation

If you know yourself well, you can know others. If you conquer yourself, you can also conquer others. If you study your mind, you can also study the minds of others. If you control yourself, you can also control others. If you are aware of your own psychology, you can also know the Psychology of others. Indeed, Man is the epitome of the Universe. What is in the Universe, is also there in the man itself. By utilizing the entire brain powers, he can see the entire universe even by closing his eyes. In the process of organic evolution, man is bipedal in nature, and erected in posture, so that brain and spinal nerve are in vertical position, against the Earth Gravitation. Spirituality is an evolution of psychology. The ultimate aim and objective of Spirituality is to make the man to attain total freedom and experience of the universalconsciousness. Vedic knowledge and wisdom is the basis for Spirituality. Vedas have neither beginning nor ending. They are the accumulated knowledge and wisdom of the Spiritual laws, discovered by different persons at different times. The discoverers of those Laws are known as Seers. It is imperative on our part to praise and honor them as the perfect human beings. That discovery was started 8000 BC and ends at 6000 BC. Decades together Aryas are in total silence and got specific answers for important questions like...

- 1) Who Am I ?
- 2) From where I have come ?

- 3) How the physical World is formed ?
- 4) To where it is merged ?
- 5) What is the purpose of human life ?

After attaining total freedom they have discovered Spiritual truths through Vedas. Vedam is God... It is the Universe... It is the Parabrahman. Even by closing their eyes, they saw the entire universe with their unlimited inner consciousness. From the inner consciousness they described the outside nature with divine Sanskrit Language which is scientific and formulated according to the vocal system of the human beings. They declared the materialistic Anatman also as God. The soul state from which vedas have come out is RidhambharaPragna. The divine sounds of the Sanskrit Language are known as Mantras and Slokas and the persons uttered those Mantras and Slokas are known as Rishies. At the beginning the Divine Mantras and the Slokas are directly received by their disciples from their Gurus as Sruthis. But unfortunately those who were experiencing soul state that is RidhambharaPragna, have been in decrease from generation to generation during the period from 3000 BC. Bhagavan Veda Vyas has composed all the Mantras as Vedam and divided it into 4 Parts viz., Rigveda, Yasurveda, Samaveda and Adharvanaveda. Each Veda contains 4 Parts.

- (a) Samhitam... A person who enjoys soul state, his body is fully topped up with cosmic energy of universe. At that state when he saw a form, all natural laws behind it come out as Mantras.
- (b) Brahmanam... Appling those divine sounds on that object is known as Brahmanam.
- (c) Aranyakam... Receiving that object as God into the mind is Aranyakam.
- (d) Upanishath... Treating it as God and enjoying universal consciousness is Upanishath.

The entire universe is formed from a single entity known as Parabrahman... Paramatman... or Pure consciousness. It is divided into Atma as Adharam and Anatma as Aadheyam... the first

one is non-visible while the latter is visible to our physical eyes. We can see the physical and materialistic world, but the Atman can not be seen by us with any kind of instrument. Since the Atman is always pure and changeless, materialistic world is changing continuously as creation, maintenance and destruction. Human life is also changes from time to time in the same pattern. Those who are enjoying soul state are above those three patterns. They can command the nature..they can control the Panchabhutas. They can do Miracles as well as wonders. They may have extra – sensory perception. They can materialize anything through their psychic powers. To some up, it can authoritatively be asserted that Man is “A living God”. Man was divine by birth, but his divinity was hidden by a veil of ignorance, poverty and superstitions. Our chief aim and objective is to remove this veil so that the divinity which is already exists in man might come out in open. With this we can authoritatively declare that the man is not only part of the universe, but he is a true representative of God with unlimited supreme universal consciousness. He is not the body, senses mind and intellect... He is the truth... He is the Brahman... He is the Paramatma... He is the universe... if he knows himself scientifically so...

Success is in big things.

Happiness is in small things

Meditation is nothing

God is everything.

Necessity of Spiritual Research for Sustainable Development

Vishal Rana

E-mail address: vishal.rana1980@yahoo.com

ABSTRACT:

The development should be aimed at creating a world of abundance where no one is lacking in basic needs and, together with this, high priority must be given to the efficient and economical distribution of the benefits of technology to achieve the sustainable development. Strategic vision for making educated men of virtue is the key to create a sustainable ecosystem. We can progress without being destructive if we decide to use spirituality as a personal path to God guiding us in our quest for advancement. The crucial issue is adding value to the systems and the lesson will have to be learnt fast. Many countries, societies and private enterprises have grown in the past without a formal strategic vision regarding environment conservation. The merit in organized thinking must be recognized. Business models should include strategic sustainable practices. Industry leaders should be self regulating. Public education in environmental science must be made a part of curriculum for all branches of study and lastly governments should craft and implement reasonable legislation to deal with all deviations. To achieve all this spiritual training is required among all the members of the society.

Realigning environmental conservation with a spiritually satisfying path produces a glimpse of an immeasurable process. Spirituality blended with '*vasudaiḥ kutumbakam*' can be a powerful tool for this planet. Societal benefits for protecting the environment motivated by religion far outweigh the costs of doing so. We can take along policy makers who are driven by their economic agenda and also politicians with their own political interest. If we trigger off this awakening, it will be the most worthwhile strategy that will hold the future for mankind. Spirituality based research in science and technology can help mitigate all environmental threats. Treating individual behaviour, inspired by spirituality can lead to the development of viable and innovative regulatory instruments that have the prospect

of achieving 'sustainable development' at a relatively lower cost.

This paper is an attempt to know the effect of integrating spirituality in research for sustainable development by inculcating spiritualism in the human lives from the childhood, through family values, values to be taught in schools by spirituality based teachers and in profession or business application of spirituality by that human to conserve the environment and protect the same for coming generations.

Keywords: Spirituality, environment, sustainable development, research

Only when the last tree has died and the last river been poisoned and the last fish been caught will we realize we cannot eat money.
(Cree Indian proverb) [1]

I. INTRODUCTION

Once upon a time there was an argument between God and a scientist. The scientist claimed that he could create the things that God had made. God took some sand and clay and made a human being. The scientist picked up the sand and clay to attempt to do the same. "Drop the sand and clay," God told him. "This was not made by you." (Dr. Murali Vallabhan, Reader, Department of Economics, SVRNSS College, Vazhoor) [2].

We should have the feeling from the bottom of our hearts that we should save the earth and cognitive thinking should be done regarding how to save the earth. Union of thinking and feeling comes from spirituality. Real spirituality is one that teaches us that the whole world is one. Global quality can be improved by implementing change that ensures dignified life for all and foster all human rights. These changes must embrace the abolition and mitigation of widespread state of affairs of poverty, joblessness, and unfair social conditions. Sustainable development ensures well-being of all individuals by integrating social development, economic development, and environmental preservation and fortification.

Spirituality:

Religion was predominantly associated with formal/organizational religion, while spirituality was more often associated with closeness with God and feelings of interconnectedness with the world and living things. Religion focuses more upon the specific group and the organization, while spirituality is more generic, and may even encompass more than one religious approach.

An individual leader may embody many of the values and practices associated with spirituality such as demonstrating respect and caring for others, but never consider herself to be a spiritual person. However, an expert in the field of spirituality, using the criteria set out by many different paths, would probably evaluate that leader as an example of spiritual behavior and values. On the other hand, a person may profess spirituality but fail to reflect spiritual values in his behavior, as in the case of clergy abuse. In other words, ethical behavior is required to demonstrate spirituality, but spirituality is not required to demonstrate ethical values and practices. This analysis focuses on traditional spiritual values and behavior as related to measures of leadership effectiveness rather than spiritual faith or intention

Spirituality gives people the strength to sustain their action throughout their lives. Sustainable development cannot be achieved unless we determine ourselves to rejuvenate the relationship between we, the people and the environment. But the question is how to orient ourselves to reestablish this vital relationship. The answer to this is Spiritual Ecology, which is a response to this crisis. Spiritual Ecology acknowledges the critical need to make transition from the physical world towards spiritualism so as to respond to the ecological crisis. It address the need to realize that the world is much more than just the physical world we perceive through the senses, just as we are much more than just our own physical bodies. There is vast environment beyond the physical world and there is spirituality beyond our physical surface. In a world of social disintegration and individual loss of meaning, spirituality offers a sense of responsibility towards the whole environment.

Sustainable Development:

"Sustainable development is development that meets the needs of the present, without compromising the ability of future generations to meet their own needs". The concept of sustainable development can be interpreted in many different ways, but at its core is an approach to development that looks to balance

different, and often competing, needs against an awareness of the environmental, social and economic limitations we face as a society. Living within our environmental limits is one of the central principles of sustainable development. One implication of not doing so is climate change. But the focus of sustainable development is far broader than just the environment. It's also about ensuring a strong, healthy and just society. This means meeting the diverse needs of all people in existing and future communities, promoting personal wellbeing, social cohesion and inclusion, and creating equal opportunity. Not necessarily. Sustainable development is about finding better ways of doing things, both for the future and the present. We might need to change the way we work and live now, but this doesn't mean our quality of life will be reduced.

A sustainable development approach can bring many benefits in the short to medium term, for example: Savings - As a result of SDC scrutiny, government has saved over £60m by improving efficiency across its estate. Health & Transport - Instead of driving, switching to walking or cycling for short journeys will save you money, improve your health and is often just as quick and convenient. So also by inculcating spirituality among human beings their lust towards physical matters will reduce and in turn help to save natural resources for future generation and thereby achieve sustainable development.

The satisfaction of human needs and aspirations in the major objective of development. The essential needs of vast numbers of people in developing countries for food, clothing, shelter, jobs - are not being met, and beyond their basic needs these people have legitimate aspirations for an improved quality of life. A world in which poverty and inequity are endemic will always be prone to ecological and other crises. Sustainable development requires meeting the basic needs of all and extending to all the opportunity to satisfy their aspirations for a better life. The living standards that go beyond the basic minimum are sustainable only if consumption standards everywhere have regard for long-term sustainability. Perceived needs are socially and culturally determined, and sustainable development requires the promotion of values that encourage consumption standards that are within the bounds of the ecological possible and to which all can reasonably aspire. The human mind made a fateful decision during the course of the Scientific Revolution; that of ignoring the perennial wisdom of the world's spiritual

traditions. Scientific research and development seemed to bring to the world technological superiority over nature. Lacking in the austere self discipline of knowledge and impelled by greed, man has tried to become a presiding deity of modern civilization. His emphasis has been on rights over obligations, particularly in the context of natural environment, leading to discernable dysfunctions in the form of environmental degradation which raises serious questions regarding the long term viability of modern society.

Satisfying essential needs depends in part on achieving full growth potential, and sustainable development clearly requires economic growth in places where such needs are not being met. Elsewhere, it can be consistent with economic growth, provided the content of growth reflects the broad principles of sustainability and non-exploitation of others. But growth by itself is not enough. High levels of productive activity and widespread poverty can coexist, and can endanger the environment. Hence sustainable development requires that societies meet human needs both by increasing productive potential and by ensuring equitable opportunities for all. A society may in many ways compromise its ability to meet the essential needs of its people in the future - by overexploiting resources, for example. The direction of technological developments may solve some immediate problems but lead to even greater ones. Large sections of the population may be marginalized by ill-considered development.

The settled agriculture, the diversion of watercourses, the extraction of minerals, the emission of heat and noxious gases into the atmosphere, commercial forests, and genetic manipulation are all examples of human intervention in natural systems during the course of development. Until recently, such interventions were small in scale and their impact limited. Today's interventions are more drastic in scale and impact, and more threatening to life-support systems both locally and globally. At a minimum, sustainable development must not endanger the natural systems that support life on Earth: the atmosphere, the waters, the soils, and the living beings. Growth has no set limits in terms of population or resource use beyond which lies ecological disaster. Different limits hold for the use of energy, materials, water, and land. Many of these will manifest themselves in the form of rising costs and diminishing returns, rather than in the form of any sudden loss of a resource base. The accumulation of knowledge and the development of technology can enhance

the carrying capacity of the resource base. But ultimate limits there are, and sustainability requires that long before these are reached, the world must ensure equitable access to the constrained resource and reorient technological efforts to relieve the presume.

In essence, sustainable development is a process of change in which the exploitation of resources, the direction of investments, the orientation of technological development; and institutional change are all in harmony and enhance both current and future potential to meet human needs and aspirations. The current terrible environmental crisis demands a spiritual retort. The fundamental requirement is inner consciousness of individuals towards deep commitment towards the earth. The scientific quest and the spiritual quest are two great quests that take its roots from spirituality. The scientific quest is about discovering the essence of world space, time, energy and matter. The spiritual quest is to discover order in our consciousness.

Spirituality And Research:

The rising popularity of spirituality is accompanied by a flood of research in numerous disciplines to probe its relationships with health, wellness, and countless other topics. The popularization of spirituality is accompanied by expanded recognition of the centrality of religion in human societies and a surge of interest in studying spiritual phenomena. Empirical research on and related to spirituality has rapidly expanded since the late 1980s in the social and behavioral sciences, social work, nursing, medicine, neurobiology, and other academic specialties and applied professions. It matters not whether popularization stimulated scholarly investigations or reflected the growing recognition that spirituality is important, for they are closely interrelated. Initially, everything now considered to be spiritual phenomena was subsumed under the concept of religion. Reinterpreting details of religion, research reveals inclusion of numerous variables and concepts that now would be classified as "more spiritual than religious". Religion and spirituality are very complex multidimensional phenomena. All research on spirituality is incomplete and imperfect. Despite significant progress, especially since the late 1980s, it still is in its infancy [3]. Spirituality is so comprehensive, universal, and all-inclusive that humans can apprehend only miniscule bits and pieces that are but tiny samples reflecting its amazing totality. In the final analysis, spirituality is "the demonstration of the Spirit. It is an action of its

originator, the soul, i.e., spirit”[2]. Because we are spirit, it is impossible to separate ourselves from spirituality to study it with unbridled objectivity, and many of its immaterial aspects are outside and beyond the bounds of scientific observation.

Religiousness and spirituality have a cumulative effect on health across the life course that we may see most clearly only later in life. Studies of mortality rates among Seventh Day Adventists [3], for example, show that the earlier the age at entry into the religious practice, the lower the mortality rate from cardiovascular disease. Meditating, yoga, fasting, walking a prayer circle, making a pilgrimage, taking the sacraments, saying daily prayers, or contemplating a sunset or a mountaintop view are all spiritual and religious practices undertaken by many of us in our daily lives, at special seasons of the year, or maybe just once in a lifetime. Some practices begin early in life and stretch back to our childhoods, while others may be sought out in adolescence and young adulthood, representing new paths. What all of these practices have in common, however, is the way in which they integrate different aspects of our human experience – our emotions with our intellect or our minds with our bodies – while also connecting us with others who share similar beliefs. We seek out these experiences, which are special and set us distinctly apart from our mundane and ordinary daily lives. These experiences lift us up out of our narrow selves and give us a glimpse – if only temporary – of another way to view things as a part, however small, of a larger picture. Spiritual and religious practices that help us integrate the body, mind, and spirit, also provide psychological and physical benefits, as research from the past two decades has shown.

Scientific research on the material universe is rapidly expanding human knowledge of both - its vastness and its intricately interacting minute parts, processes, and relationships. Similarly, research on spirituality is expanding our perceptions toward both an ever broader awareness of its vast domains and a deeper discernment of its largely impenetrable components, processes, and influences. As we continue to study snippets of spirituality and its manifestations both within and outside of religion, we will generate increasing light on its complexities and expanding wisdom for its applications to social and individual behavior. Yet far beyond the scope of research methods related to spirituality and their findings, there forever is more and more and more.

Scenario of Integrating Spirituality in Research for Sustainable Development:

In the words of Swami Vivekananda, “*Religion is the idea which is raising the brute unto man and man unto God*”. The religion refers to both the personal practices related to faith as well as to the larger shared system of belief sourced from spirituality. Practicing the tenets of spirituality of the world, we can save the earth from extinction. If we look at society from a historical perspective, we realize that protection and preservation of the environment has been integral to the cultural and religious ethos of most human communities. Ancient Hindus, Greeks, Native Americans and other religions around the world have acclaimed nature. Many saints say that love for one another (human brotherhood), love for all creation (biotic and abiotic) and love for oneself are religion. Spirituality teaches us that the earth is sacred, the fact that traditionally helps to exert control over how people interact with the natural world. The use of spirituality as a tool for environment conservation is justified because firstly most lasting social change is anchored in a deep moral imperative. Secondly values based rationales for protecting biodiversity are widely held and persuasive. Thirdly it humanizes and personalizes choices about environment and more importantly, understanding ethics backed by individual’s religions will help us make better decisions on complex issues. Human needs and desires are endless. There is lack of emotions and insensitivity towards relationships.

The sustainable development is about balancing the human needs with environmental protection. It is equally important that humans should be allowed to grow and develop but the sad part is that the rate at which they are growing is destructive in nature. A better plan for sustaining resources is needed especially the four main areas that need to be sustained are - the natural environment, industry, agriculture, and the social needs of humanity. People with materialistic behavior consider physical matter as the only component of reality. Personal satisfaction and greed are the most important aspects of life of the society driven by materialism. It acts like a brainwasher and removes the sense of responsibility towards our ecosystem. Materialistic-dominated culture use to consider nature and the earth as a material and mechanical object, instead of acknowledging the interdependence of the ecosystem. The sad part is that people are forgetting their ethical and moral values and often fail to understand the

distinction between right choices and the wrong ones. The only thing that people give much importance is good quality physical life and false comforts. They think that everything around them is dictated by need of humans and the environment is compelled to provide this. However, an increase in materialism has actually slight or no effect on the well-being and contentment of its people. Thus materialism has unfavorably affected the complete framework of our society. The consciousness or awareness of a connectedness to everything will facilitate us to move towards the aspiration of sustainability. Though we human beings have exploited our environment through our interventions and have produced the problems facing our planet earth, yet we have this inherent ability to take corrective actions. All it requires is fundamental changes in human attitudes and behavior. This fundamental change calls for a transition of core self from ordinary to spirituality. It is about our honesty to assimilate the significance of interdependence and interconnectedness of all forms of life. Ecology is the relationship between organisms and their environment. "The spiritual part can refer to religion but it doesn't have to. There are many people who don't consider themselves religious, yet they consider life sacred. Spiritual ecology alludes to a deeply felt personal transformation in the way we relate to our environment" [1]. But the lack of spiritual orientation in the people has resulted in the crisis of the relationship between man and nature. There is need for spirituality in the environmentalist movement. Spirituality gives people the strength to sustain their action throughout their lives. Sustainable growth cannot be achieved unless we determine ourselves to rejuvenate the relationship between we; the people and the nature. To establish this relation Spiritual Ecology best solution. The Earth has a body that is very much like our body. When there is some setback she heals herself. But like our body, if the body is exploited again and again and filled with more and more toxins and is never given the time to recover itself, then it can't heal itself and the result is serious diseases. When Mother earth gets a disease the reactions are severe earthquakes and tsunamis. It is necessary, therefore, to clean the ecology of our consciousness and the simplest and most powerful agent to remove the pollution of our minds and hearts and restore the love, compassion and inner satisfaction that we are all longing for is the inculcating spirituality among ourselves.

The golden threads connecting spirituality and sustainability included relationship, sacredness, consideration, significance and accountability/reciprocity. It was determined that one cannot achieve sustainability in the absence of a strong personal intuitiveness that comprise of spirituality. Overall, it is our inner consciousness and love that act as a glue that binds all of the connections and is thus essential for achieving any level of sustainability and world transformation.

The sustainable development is intimately linked to the dynamics of population growth. The issue, however, is not simply one of global population size. The sustainable development can be pursued more easily when population size is stabilized at a level consistent with the productive capacity of the ecosystem. The control in population can be more effectively achieved by spirituality than by medical means which in turn leads to foeticides.

If needs are to be met on a sustainable basis the Earth's natural resource base must be conserved and enhanced. Major changes in policies will be needed to cope with the industrial world's current high levels of consumption, the increases in consumption needed to meet minimum standards in developing countries, and expected population growth. However, the case for the conservation of nature should not rest only with development goals. It is part of our moral obligation to other living beings and future generations. Sustainability requires the enforcement of wider responsibilities for the impacts of decisions. This requires changes in the legal and institutional frameworks that will enforce the common interest. Some necessary changes in the legal framework start from the proposition that an environment adequate for health and well-being is essential for all human beings including future generations. Such a view places the right to use public and private resources in its proper social context and provides a goal for more specific measures. Many of the nations including India enacted Environmental Protection Laws, and also developed legal procedure for the actual protection and punishing the violators, but at the outset we can say that everything can't be achieved by law but self discipline is necessary for which integrating spirituality in every personality is essential.

II. CONCLUSIONS

Government's initiatives and efforts, and other efforts such as "Earth Day", "Earth Hour" by

several other environmental organizations may help to reduce the negative impact, but it's not enough, we must understand that unless there is a change in consciousness, there would not be sustainability. Consider the recent movement regarding cleaning of the river Yamuna, Ganga where people in large numbers marched to Delhi to put political pressure also filed various writ petitions for stopping the polluted water in these rivers, but it is quite evident that we cannot clean the rivers unless we clean our hearts because then only people will not pollute the rivers again. We have to clean our hearts and fill it with consciousness. We are all - the earth, nature and humans are all part of ecology cycle and once this cycle affects, all of us would be no more. Therefore, the primary emphasis should be to imbibe certain values which focus on environmental protection, and link these to the core faith/ beliefs or spirituality of the people. The much required ideological change should be to appreciate life quality rather than constantly running after an increasingly comfortable, materialistic higher standard of living. The awareness about our unity and interdependence with nature needs to be created for a better future. An individual sense of existence and identity needs to be replaced by the "experience of profound interconnectedness with all life" and a foundation can be laid through a spiritual awakening towards protection of all and against all forms of exploitation. To arrive at this state, we need to make a journey from the outer materialistic behavior towards closed doors of spirituality. In the midway lie our neglected emotions and relationships which we need to embrace so as to open the closed door of our innermost manifestation, i.e. spirituality. The word "Spirituality" is about finding answers for the questions: "What am I supposed to do with my life?" One possible answer to this question leads us to see the human species as the change-agents in this world. We are through our each and every action causing changes in this world and environment, it is only a matter of realigning our priorities, and create positive changes, which can ensure a healthy living for ourselves, our future generations and for all life forms.

We must realize and work considering the wise saying that - "*We do not inherit the earth from our ancestors, we borrow it from our children*" [4]. We should also use our new age thinking to create awareness and urgency towards saving the planet through scientific, rational as well as spiritual approaches. We have to create an inspiring and competent change

agent within us who has the courage of conviction which in turn will trigger off the process of sustainable growth. This is how we move towards a Holistic World View- a view of collectivism rather than individualism. We should not look for the change agents; rather take the role of change agents. To be a change agent is a state of mind in the same way as is to be contented and happy. We must understand that we are an integral part of the environment; therefore we can be observers and change agents. Even one thought, one touch, one glance can make difference! This is how we can induce and produce positive changes in the environment so as to sustain it, which in turn will sustain us. We need to go for self-introspection and questions to ourselves. It is important that we associate sustainability with enabling imaginative, progressive change at all levels, from individual to species to biosphere, from home to planet. For promoting conservation, protecting vital ecosystems, preventing undue climate changes, securing water accessibility, or reducing air pollution, we should develop and execute innovative solutions to critical environmental problems.

Every research done be aimed for sustainable development but through spirituality, i.e. without disturbing the ecology we have to invent the things for human comforts. For ex. Using eco-friendly bricks to construct a house than cement which is produced after destroying environment. All types of the development should be aimed at creating a world of abundance where no one is lacking in basic needs and, together with this, high priority must be given to the efficient and economical distribution of the benefits of technological development. All scientists and decision makers must have a solid grounding in ethics, ecology and public safety. Strategic vision for making educated men of virtue is the key to create a sustainable ecosystem. Industry leaders should be self regulating. Public education in environmental science must be made a part of curriculum for all branches of study and lastly governments should craft and implement reasonable legislation to deal with all deviations. Societal benefits for protecting the environment motivated by spirituality far outweigh the costs of doing so. We can take along policy makers who are driven by their economic agenda and also politicians with their own political interest. If we trigger off this awakening, it will be the most worthwhile strategy that will hold the



future for mankind. Together the spirituality and research of the world can help mitigate all environmental threats.

This will create self directed individual action followed by group directed action. “Realigning environmental conservation with a spiritually satisfying path produces a glimpse of an unfathomable process” [1]. Spirituality blended with ‘*vasudaiiv kutumbakam*’ can be a prevailing tool for the achievement of the sustainable development.

REFERENCES

- [1]. Mrs. Nandita verma, RELIGION : A SAVIOUR FOR ENVIRONMENT WITH PARTICULAR EMPHASIS ON HINDUISM, available at www.Context and Human Resource-04-Nandita Verma.pdf visited on 05/09/2016
- [2] Ibid.
- [3] David O. Moberg, Spirituality Research: Measuring the Immeasurable?, available at www.PSCF6-10Moberg.pdf visited on 05/09/2016
- [4] Akanksha S. Chatterjee and Aneesya Sharma, Role Of Individuals As Change Agent For Sustainable Development: Integrating Spirituality And Ecology, ISSN: 2278 – 7798 International Journal of Science, Engineering and Technology Research (IJSETR) Volume 2, Issue 5, May 2013 available at www.IJSETR-VOLUME-2-ISSUE-5-1199-1203.pdf visited on 05/09/2016

On realization of cosmic energy and on realization of natural wisdom

V. Anantha Padmanabhan

Pollachi, Tamil Nadu 642006, India
Email: ananta.primes2015@gmail.com

ABSTRACT:

In this paper, the author explains what is realization of cosmic energy which is well known and certain types of meditative practices to realize it. During this course of meditation or at the completion of this meditation, a yogi may realize or visualize some mental images. Some of the yogis' may not give due importance to such images because their goal and soul aim is to realize a particular state of mind through their meditative practices. These images may not be all illusions; some may be related to natural wisdom. On going on developing thoughts on those images one may attain new thoughts in philosophy, science, mathematics and arts. So, the yogi should not ignore any images that he realizes during his course of meditation.

I. INTRODUCTION

There are so many types of meditations. Osho Rajneesh explains in his book "On meditation" some 108 types of meditational systems.

In the article available [1] the author explains five simple steps to practice spiritual meditation. The author also narrates about types of meditations as follows:

To quote the author, there are different types of meditative techniques that have been extensively used by our forefathers and are successfully used even today. Generally, meditation is sub divided into many types. They are:

- 1) Concentration
- 2) Creative meditation
- 3) Mindful meditation

- 4) Heart centered meditation
- 5) Reflective meditation

Every type of meditational system has its own purpose. Concentration meditation is designed to help stimulate and enhance one's concentration. Zen, Om, sacra Samadhi, transcendental meditations are the some of the techniques.

Creative meditation helps boost creativity and feelings, appreciation, joy, patience, compassion and love.

Mindful meditation helps one to connect better with people and environment.

Heart centered meditation usually helps one to build feelings of love, kindness and compassion. This technique is especially effective for people who suffer from heart diseases.

Reflective meditation usually helps one to reflect on a situation occurrence or a question that has been troubling him. The key thing here is to select the theme and reflect up on the questions and answers.

The author suggests measured breathing exercises also.

General aim of these types of meditation is to bring forth into oneself the cosmic energy by practicing cosmic energy meditation.

In this paper, the author does not make any difference with the author of the article cited in [1] but the author is adding one more fact about realization of natural wisdom.

A yogi may attain the natural wisdom during the course of the said cosmic energy realization meditation or at the competitions of the meditation. Some of the yogis may not know the

importance of the natural wisdom. So, the author emphasizes the importance of the natural wisdom.

II. Realization of cosmic energy

Cosmic energy is the life force that is existence everywhere. As per philosophical system, very particularly the Hindu philosophical system, the cosmic energy is otherwise known as spiritual energy, and it is also referred to as Prana. The Kashmir Shaivism elaborately discusses this. Again, some new age authors states this energy as quantum vacuum zero point energy and or as orgone energy. As per certain yogic system it is a source of kundalini.

As per scientific thought, cosmic energy (Cosmology) means the cosmic microwave background radiation, the left over radiation from the big bang.

In the studies of quantum physics it is referred to as quantum vacuum zero point energy or physical cosmology or dark energy.

In this paper, the author's aim is not to state or argue or to explain about the existence of black energy. Simply the author's aim is not to state here any kind of arguments either in favor or refusal, on the existence of black energies which is purely a scientific study. Different authors may raise different views and opinions in this regard.

In short, it is everyman's experience that everyone of us is realizing that a lot of energy from the external universe. As if one is getting energy from sun and moon and from the milky way, everyone is getting energy from the milky way, the distant stars, galaxies and the the remote expanding universe.

All the people are getting energy showered by the universe. A deep study in the vedic literature may reveal more facts.

In general, people are realizing the cosmic energy during sleep than in the awakening state.

So, it is needless to say everyone should go for correct sleep.

By meditating on such energies in one or other name and practicing one system or other, more potentiality develop in himself, maintain good health, get healed certain deceases etc. control blood flow, and control mental trust, state of anxiety, depression etc.

By practicing cosmic energy, as cited in the reference [1] or in any other system or any other meditative system, or self styled technique by one himself, a yogi is getting more energy, bliss, happiness, free from ill health and get gets his personal problems solved and increases his creativity.

This is the essence of various cosmic energy meditative practices which is being practiced very particularly IN India from ancient time.

III. Realization of natural wisdom

While practicing cosmic energy meditation, one may limit or neutralize his thought or one may go on increasing his thoughts as per the system meditational system that he practices. Yogis may attain their goals.

In addition to this, some may realize their natural wisdom just awaken during this course of meditation. This is not awakening of the soul ore a practice of self realization etc and this is not hearing the sound from the cosmos, that is asariri or hearing the inner voice.

And this is not the rise of one's own memory- the memory of present or past life.

This is a rise of visual of so many visions or mental images which is called natural wisdom and should ne noted all such images are not related to natural wisdom.

Some may relate to God realization, if the yogi set a goal for it. The natural wisdom that has been realized may be related to the studies of philosophy, science, mathematics or arts. It all depends up on the yogi's interests which he developed from his boyhood.



If the yogi on later dead sits and develops his thoughts he may be able to arrive new result in the above said area of studies. A yogi should not waste any of his realization.

IV. CONCLUSION

Through this paper the author wishes to emphases that the human mind and its various parts including the physical brain consists of a treasure. A lot of mystics are lying in understanding his various functions and its capacities. In addition, its valuable TREASURE everyman or woman is receiving the cosmic energy which also develops one's potentiality. A yogi who practices cosmic energy meditation for raising his energy into himself and produces good results for the benefit of the entire human kind.

REFERENCES:

- [1] <http://www.stylecraze.com/articles/what-is-cosmic-energy-meditation-and-what-are-its-benefits>
- [2] <http://naturalwisdom.blogspot.in/>

Performance of Evaporators and Various Parameters: A Review

Aijaz Husain¹

B.E., Chemical Engineering, SSBT's COET, Bambhori, Jalgaon, (M. S.), India
ajajansari81@yahoo.in

Kalpesh Patil²

B.E., Chemical Engineering, SSBT's COET, Bambhori, Jalgaon, (M. S.), India
Princekalpesh8436@gmail.com

Dr. S. A. Thakur³

Assistant Professor, Chemical Engineering, SSBT's COET, Bambhori, Jalgaon, (M. S.), India
satsan17@rediffmail.com

ABSTRACT:

The literature review presents a brief study about steam consumption, steam economy, heat transfer area, efficiency, overall heat transfer coefficient in different systems. The evaporators used for the study shows that steam economy and overall heat transfer coefficient plays major role in steam consumption. The evaporator performance is also strongly related to total heat transfer coefficient.

Key words: evaporator, steam economy, steam consumption.

INTRODUCTION

Evaporators are kind of heat transfer equipment's where the transfer mechanism is controlled by natural convection or forced convection. A solution containing a desired product is fed into the evaporator and it is heated by a heat source like steam. Because of the applied heat, the water in the solution is converted into vapour and is condensed while the concentrated solution is either removed or fed into a second evaporator for further concentration. If a single evaporator is used for the concentration of any solution, it is called a single effect evaporator system and if more than one evaporator is used for the concentration of any solution, it is called a multiple effect evaporator system. [9]

Minimum steam consumption to achieve maximum steam economy is dependent on feed preheating by condensate, vapour bleeding, thermo compression & optimum flow sequence.

LITERATURE REVIEW

Wani et.al. (2014), studied that, the development of a multi evaporator system (3 evaporators) to maintain the different operating temperature in evaporators with a single compressor, an individual expansion device and an air cooled condenser. This system is used to maintain -10°C , 0°C and $+10^{\circ}\text{C}$ in three compartment. An air conditioner compressor of 1.5 tons is used for the setup purpose. Refrigerant R-22 issued for system. Multi evaporator systems yields the higher value of coefficient of performance compared to single evaporator system meant for different temperatures. There is easy control of fluctuations in loads by controlling individual evaporator. The combined action of the thermostatic expansion valve and back pressure valve allows the cooling capacity at the evaporator to be controlled for testing of evaporator under various heat loads. The result of the test conducted by change in load on evaporators shows that with increase in load on any evaporator, power consumed by compressor increases. It is found that comparatively total load on evaporator is more than power consumed. Hence coefficient of performance increases with increase in load. Also saving in initial cost and space required are the additional advantages with single compressor multi evaporator systems. [1]

Salakki et.al. (2014), experimentally studied that evaporation and cooling are the common techniques used to extract available salts and reusable water. The pharmaceutical industry of the study uses multiple effect falling and forced circulation evaporator to achieve zero liquid discharge process for pharmaceutical effluent. They studied that the former tests revealed

leakages in various parts of the multiple effect evaporator. The leakages were arrested and high pressure cleaning along with chemical cleaning was performed to remove the scaling in the evaporator. This improved the efficiency of the multiple effect evaporator significantly resulting in reduction of chemical oxygen demand and total dissolved solids by 91.5% and 96% respectively. This also achieved reduction in energy consumption by 40% reducing the overall live steam consumption from 0.55 to 0.32 kg/kg of effluent treatment. The major physico-chemical parameters chemical oxygen demand (COD), total dissolved solids (TDS) and pH were analyzed for the feed and condensate of the Multiple Effect falling film and forced circulation Evaporator (MEE). Characterization of condensate from the MEE showed COD and TDS as 430 ppm and 3600 ppm respectively. As per the design specification the condensate should have COD and TDS values below 250 ppm and 2100 ppm respectively. This showed the Performance of the MEE can be improved by arresting the leakages and removing the scale formed by high pressure and chemical cleaning processes. [2]

Balpande et.al. (2014), studied that with addition of each effect steam economy of the multiple effect evaporators increases. Evaporators are the major part of major chemical process industries from paper pulp to fine chemicals. The evaporators requires huge amount of steam, so proper optimization of evaporator set up can to improve an efficiency of system and it ultimately leads in reduction of an operating cost. In the present system it consists In this proposed work four different control configurations are studied, in order to achieve the end target of attaining the value of concentration accurately. A simple PID controller was first designed with a feedback control, then taking into consideration of disturbances on the process, a feed forward control was then employed to overcome that effect. Later using a concept of BPR to determine the concentration was used, which is more accurate than using conventional concentration measuring sensors and less cost of their purchase. Combining all this together gives an improved PID controller for single effect evaporator. A single effect evaporator is not commonly used to

Walter (2007), performed stability analysis on a vertical type natural circulation heat recovery steam generator. The evaporator of the boiler

of four effects which work at maximum operating efficiency. This system operates in line with secondary circuit to get an equivalent quantity of low pressure steam. The system operates at high pressure as against a conventional vacuum evaporation system & this paper mainly consists of design aspects of multiple effects evaporator system like area calculation, heat & mass balance, heat transfer coefficient, evaporator scheme etc. He optimized and concluded various parameter as, Feed Rate = 4700 Kg/Hr, Concentrated output = 565 Kg/Hr, Water Evaporated (Kg/Hr) = 4135 kg/hr, Boiler steam consumption (14.5 Bar) = 2021 kg/Hr, Low Pressure Steam Produced (2.5 Bar) = 1687 Kg/Hr, Actual steam consumption = 2021-1687=334 kg/Hr, Steam Economy (Kg water evaporated/ kg steam) = 12.38. [3]

Tijjani et.al. (2016), studied the Kraft pulping process that is mostly used in paper mills. This is because the chemicals used in cooking are being recovered, and environmental pollution is minimized, as the chemicals are not discarded into the environment, but rather recycled. Feeding the black liquor directly from the digester to the recovery boiler will cause a water/smelt explosion. This explosion happens if the percentage of water in the liquor is high, the solid content of the black liquor leaving the digester is usually between 13-18%. To avoid such disaster the concentration of the black liquor has to be increased, which should be in the range of 60-70%, this is done in a single or multiple effect evaporator. [4]

consists of four parallel horizontal tube paths, which are connected at both ends with headers. For different operation pressures and geometries the dynamic instability and in particular the density wave oscillation (DWO) were analysed. The investigations show that the stability of the boiler can be improved by increasing the system pressure. A faster decay of the DWO can be achieved by the implementation of an orifice at the tube inlet of the evaporator (single phase flow), whereas the installation of an orifice at the tube outlet (two phase flow) results in a more unstable behaviour. To improve the stability the flow resistance at the inlet of all tubes (flow restriction, e. g. orifice) of the bundle heating surface can be increased within certain limits. An increase of the flow resistance at the tube outlet results in a more unstable behavior of the boiler. [5]

Kim and Kang (2002), an experimental study has been conducted to investigate the effects of hydrophilic surface treatment on evaporation heat transfer at the outside wall of various kinds of copper tubes. Plain, spiral, corrugated, and low-finned tubes were selected as test tubes. In this proposed work, to increase the wettability of distilled water on copper tubes, a novel hydrophilic surface treatment method using plasma was employed. The experiments show that every kind of hydrophilic surface treated tube tested in the work exhibits superior evaporation heat transfer performance as compared with that of the same kind of untreated tube. It is found out that during the evaporation process, the high wettability of the surface obtained through hydrophilic treatment induces film flow on the tubes while sessile drops are formed on untreated tubes. Therefore, the hydrophilic coating of evaporator tubes using plasma seems to be a viable method for improving the efficiency of many thermal systems including absorption refrigerators. The underlying mechanism that enhances the evaporation heat transfer in this proposed work is that the hydrophilic treatment induces film flow rather than sessile drops onto tube surface. The film has a smaller thickness as well as a greater heat transfer area than the sessile drops, and this yields higher heat transfer rate for hydrophilic surface treated tubes than that for untreated tubes.[6]

Bustamante and Gerimella (2012), studied about the flow visualization with high-speed video of evaporating water films falling over flat horizontal tubes, representative of the external surfaces of micro channel tubes. Experiments were conducted with 1.4 mm thick and 27 mm tall tubes over a film Reynolds number range of $23 < Re < 126$. In addition to a qualitative description of the flow mechanisms, this work quantifies key droplet and wave characteristics using image analysis techniques. A semi-autonomous edge-detection technique is used to develop a mathematical description of the droplets and waves, allowing the surface area, volume, velocity, and frequency of the droplets, as well as the width, surface area, and velocity of the waves, to be measured. In an undisturbed film, pendant droplets form under tubes, impact the tube below, and initiate roll waves that travel down the vertical, flat surface. However, interactions between neighboring droplets and waves can have a substantial impact on the development of each individual droplet and wave. This process shares many similarities with

falling-film flow on horizontal round tube banks. A semi-autonomous image analysis method was used to quantify key droplet and wave characteristics. The droplet frequency, width, surface area, volume, and velocity were measured at the time of impact, and wave width, surface area, and volume were tracked during wave development on the vertical flat surface. The droplet frequency increased linearly as flow rate was increased, but the time periods between impacts exhibited stochastic behavior. Droplet width, surface area, volume, and velocity were not influenced significantly by the film Reynolds number, but velocity increased for tubes lower down in the tube bank. The wave width and surface area both increased as the wave developed. Wave velocity remained approximately constant throughout the wave travel. [7]

Zhao et.al. (2014), an experimental correlations shows the comparison for heat transfer coefficient on the outside of the evaporative tube and the heat transfer coefficient on the inside of the horizontal tube falling film evaporator. Analysis was conducted on the flow of the liquid film on the inside and outside of the evaporator tube under steady working conditions and the effects of evaporation temperature, heat transfer temperature difference, and tube diameter on the local heat transfer coefficient and the total heat transfer coefficient. Through the comparison of heat transfer correlation analysis draws the conclusions that the comparative analysis found that the applicability of the Nusselt formula is better for calculating the condensation side heat transfer coefficient and its use is recommended for estimation purposes at the beginning of the design. The analysis found that the total heat transfer coefficient k increases with increases in evaporation temperature and decreases slightly with increases in inner tube diameter.[8]

CONCLUSION

On the basis of numerical and experimental analysis being carried out in different studies on steam economy, overall heat transfer coefficient and heat transfer are analyzed on single & multiple effect evaporator, the theoretical results showed that with increase in load on any evaporator, power consumed by compressor increases. It has been observed that comparatively total load on evaporator is more than power consumed. From the literature reviews, it is also concluded that leakages can be

arrested and high pressure cleaning along with chemical cleaning can be performed to remove the scaling in the evaporator. The analysis also found that the total heat transfer coefficient k increases with increases in evaporation temperature and decreases slightly with increases in inner tube diameter.

REFERENCES

- [1] Tejal T. Wani, Amol A. Gawali, Madhav S. Joshi, Development and Performance Analysis of Multi Evaporative System, *International Journal of Engineering Development and Research*, ISSN: 2321-9939, Volume 2, Issue 2, (2014)
- [2] SachinkumarSalakki, M A Lourdu Antony Raj, Jagadish H Patil, Vikas Shetty, Improving the Efficiency of Multiple Effect Evaporator to Treat Effluent from a Pharmaceutical Industry, *International Journal of Innovative Research in Science, Engineering and Technology*, ISSN: 2319-8753, Vol. 3, Issue 7, July 2014
- [3] PRASHANT BALPANDE, PROF.G.S.ZAMRE, DR.P.V.THORAT, Heat Integration and Designing of Multiple Effects Evaporator, *International Journal of Scientific Engineering and Technology Research* Volume.03, IssueNo.41, November-2014, Pages: 8397-8400(2014)
- [4] AminuTijjani, H. K. Verma, Chhaya Sharma, DEVELOPMENT OF IMPROVED PID CONTROLLER FOR SINGLEEFFECT EVAPORATOR, *IJRET: International Journal of Research in Engineering and Technology*ISSN: 2319-1163 | pISSN: 2321-7308(2016)
- [5] HEIMO WALTER, Density Wave Oscillation in the Horizontal Parallel Tube Paths of the Evaporator of a Natural Circulation Heat Recovery Steam Generator –A Theoretical Investigation, *WSEAS TRANSACTIONS on HEAT and MASS TRANSFER*, ISSN: 1790-5044, Issue 2, Volume 2, (April 2007)
- [6] H.-Y. Kim, B.H. Kang, Effects of hydrophilic surface treatment on evaporation heat transfer at the outside wall of horizontal tubes, *Applied Thermal Engineering*, 23 (2003) 449–458 (2002)
- [7] John G. Bustamante, SrinivasGarimella, Dominant Flow Mechanisms in Falling-Film and Droplet Mode Evaporation over Horizontal Rectangular Tube Banks, *International Refrigeration and Air Conditioning Conference at Purdue*, July 16-19, (2012)
- [8] Guochang Zhao, Heng Zhao, Liping Song and Yong Wang, Research on heat transfer coefficient of horizontal tube falling film evaporator, *Journal of Chemical and Pharmaceutical Research*, ISSN: 0975-7384, 6(6):2779-2785, (2014)
- [9] V. Jaishree, Optimization of a multiple Effect Evaporator System, *DEPARTMENT OF CHEMICAL ENGINEERING NATIONAL INSTITUTE OF TECHNOLOGY, ROURKELA - 769 008*, (2010)

Review of Dimple Tube Double Pipe Heat Exchanger Design

Chetan Kharche¹

B.E., Chemical Engineering, SSBT's COET, Bambhori, Jalgaon, (M. S.), India
kharche385@gmail.com

Sushila Pawade²

B.E., Chemical Engineering, SSBT's COET, Bambhori, Jalgaon, (M. S.), India
sushila.pawade7@gmail.com

Dr. V. R. Diware³

Associate Professor & Head, Chemical Engineering, SSBT's COET, Bambhori, Jalgaon, (M. S.), India
3vrdiware65@rediffmail.com

ABSTRACT

In present review work on “dimple tube double pipe heat exchanger design” gives brief analysis of heat transfer area, friction factor, and thermal performance of dimple pipe heat exchanger. The study shows that using available enhancement method such as considering the surfaces of dimple like spherical, ellipsoidal, triangular, trapezoidal, square etc. which can provide the heat transfer rate higher than smooth tube. From the reviews it is also known that increase in turbulence intensity may be one of the reasons for increase in heat transfer.

Keywords: dimple tube, heat transfer area, friction factor, turbulent flow.

INTRODUCTION

The heat exchanger is a device used to transfer heat between one or more fluids through a medium. The concentric pipe heat exchanger is one of the different types of heat exchanger. It is also called double-pipe heat exchanger because one fluid flows inside a pipe and the other fluid flows between that pipe and another pipe that surrounds the first. In this double pipe heat exchanger a cold process fluid flowing through the outer pipe transfers its heat to hot fluid flowing through inner pipe. [9]

The dimpled tubes provide heat transfer rates that are higher than the rates found in smooth tubes under similar conditions. This is an important development for the energy conversion and process industries. It was demonstrated that more heat transfer and an earlier transition to high heat transfer can be accomplished through the use of dimpled tubes. Tubes have been

evaluated and can be designed to produce more heat transfer than smooth tubes under fouling conditions. [1]

Enhancement of heat transfer is the process of improving the thermal performance of heat exchanging devices. Efficient heat exchanging devices required in the industries are responsible for the huge development and research in the methods of heat transfer augmentation. One of the frequently used methods to improve heat transfer enhancement is by geometric modification prompting earlier transition to turbulence, creating vortices that increase mixing or restarting the thermal boundary layer to decrease its thickness. An effective method of heat transfer enhancement is required to not only improve the heat transfer, but also minimize the flow resistance as much as possible. Accordingly much research has been carried out on various heat transfer augmentations such as pin fins, louvered fins, offset strip fins, slit fins, ribs, protrusions, and dimples in order to improve the thermal efficiency of heat exchangers. Among various heat transfer enhancers, a dimpled surface shows a high heat transfer capacity with relatively low pressure loss penalty compared to other types of heat transfer enhancers that are available. Therefore, many studies have been conducted in order to determine the heat-transfer characteristics that are induced by the dimpled surface. The present review covers the heat transfer enhancement characteristics in dimple tubes. [4]

LITERATURE REVIEW

Luki.A and Ganesan.M, in their investigation studied that, augmented surface can be achieved with dimples, strategically located in a pattern along the tube of a concentric tube heat

exchanger with the increased area on the tube side. In this analysis they modify the inner tube of double pipe heat exchanger using dimpled tube. From this design the theoretical calculation shows that, heat transfer coefficient is increased compared to plain concentric tube heat exchanger. Similarly the effectiveness is 8% increased as compared to plain tube. The theoretical results shows that dimpled tube heat exchanger gives better performance. The modeling and analysis is carried out to vary the dimple tube cross sections, ellipsoidal and spherical shapes using CFD. Finally the enhanced dimple tube is compared with the theoretical, analytical and analysis results. So they suggested the dimpled tube to be used in concentric tube heat exchanger in various applications will give high heat transfer. [1]

Verma et.al. (2015), studied that the heat transfer enhancement over surface results from the depression forming recesses rather than projections. Such features are known as dimples, and may be formed in an infinite variation of geometries which results in various heat transfer and friction characteristics. Heat Transfer enhancement using dimples are based on the principle of scrubbing action of cooling fluid taking place inside the dimple and phenomenon of intensifying the delay of flow separation over the surface. Spherical indentations or dimples have shown good heat transfer characteristics when used as surface roughness. The technology using dimples recently attracted interest due to the substantial heat transfer augmentations it induces, with pressure drop penalties smaller than with other types of heat augmentation. From all the research work they had studied, the researchers have used various dimple shaped geometries such as triangular, ellipsoidal, circular, and square out of which ellipsoidal shape gives better results due to prior vortex formation than other shapes. [2]

Thianpong et.al. (2009), experimentally investigated about friction and compound heat transfer behaviors in a dimpled tube fitted with a twisted tape swirl generator using air as working fluid. The effects of the pitch and twist ratio on the average heat transfer coefficient and the pressure loss are determined in a circular tube with the fully developed flow for the Reynolds number in the range of 12,000 to 44,000. An experimental study of fully developed turbulent flow in a dimpled tube in conjunction with a twisted tape has been

performed. The influences of the pitch ratio and twist ratio on the heat transfer rate and friction factor characteristics have also been investigated. A dimpled tube in common with a twisted tape has significant effects on the heat transfer enhancement and friction factor. The heat transfer and friction factor are increased with decreasing both of pitch ratio and twist ratio. Depending on the pitch ratio and twist ratio, the heat transfer rate and friction factor in the dimpled tube with twisted tape, are respectively 1.66 to 3.03 and 5 to 6.31 times of those in the plain tube. [3]

Banekar et.al. (2015), experimentally studied the heat transfer enhancement for almond shape dimple array geometries at Reynolds no range 3000 to 6000. Results have been obtained experimentally. They have concluded that, the computations and the measurements are in good agreement with each other. The maximum increment between the experimental heat transfer enhancement coefficients for the dimple tube over plain tube was found to be 12.7% and the experimental and numerical results both show that the almond shape dimple geometry provides the highest heat transfer over the plain tube in this study. From the experimental calculations it was found that Effectiveness of dimple tube over plain tube is increased by 21.95%. [4]

Patil and Deshmukh (2014), studied that, the heat transfer coefficients were measured in a circular tube with dimpled surface. The Reynolds number based on the channel hydraulic diameter was varied from 25000 to 95000. An experimental study was conducted for the staggered configuration of the dimple and compared with the base line results of plain tube. It was found that staggered array of dimple in circular tube has 66% greater thermal performance factor than aligned dimple configuration. Their study focused on investigating whether the use of almond dimples can enhance heat transfer characteristics for a circular tube. The staggered dimpled array geometries on the wall of a tube were tested for four different Reynolds numbers ranging from 25795 to 94594. Nusselt number increases about 28 to 30 % experimentally and 47 to 60% numerically in staggered array, and by analytical prediction it is almost found to be same. Variations in experimental, analytical and theoretical values are because of manufacturing and measuring errors. Enhancement efficiency obtained by almond shape experimentally about 2

to 4 % greater than plain tube. The computations and the measurements are in good agreement with each other. The maximum error between the averaged experimental heat transfer enhancements with numerically predicted enhancement is 25%. [5]

Sardar and Kaladgi (2015), Showed that dimples play a very important role in heat transfer enhancement of electronic cooling systems, heat exchangers etc. This work mainly deals with the experimental investigation of forced convection heat transfer over circular shaped dimples of different diameters on a flat copper plate under external laminar flow conditions. Experimental measurements on heat transfer characteristics of air (with various inlet flow rates) on a flat plate with dimples were conducted. From the obtained results, it was observed that the heat transfer coefficient and Nusselt number were high for the copper plate in which the diameter of dimples increases centrally in the direction of flow. [6]

kumar et.al. (2014), studied that the heat exchanger device such as concentric tube heat exchanger faces challenges to obtain the best thermal performance of heat exchanger devices plays important role in the performance of cooling system. In the present work, a concentric tube heat exchanger has been numerically modeled for heat transfer and a pressure drop characteristic under different flow rates are investigated. Reynolds numbers for the inner tube ranged from 1000 to 5000. The overall heat transfers were calculated in parallel heat exchanger. CFD Analyses were carried out with flue gas in the annulus side and Al₂O₃ Nanofluid in the inner tube side. The numerical results indicated that the Nusselt number for the spherical dimpled tube and ellipsoidal dimpled tube are 35.7% and 63.59% higher than that for the smooth tube in same Reynolds number. The friction factors in the dimpled tube increase by 52.7% and 87.27% for ellipsoidal and spherical dimples compared to the smooth tube. Heat transfer rate of spherical dimpled tube with Al₂O₃ Nanofluid is 40% better than in the plain tube and ellipsoidal dimpled tube with Al₂O₃ Nanofluid is 46% better than in the plain tube with Al₂O₃ nanofluid. Thus, the ellipsoidal dimpled tube could enhance heat transfer more efficiently than smooth and spherical dimpled tube with Al₂O₃ Nanofluid. [7]

Vyas et.al. (2016), studied about design, manufacture and evaluation the performance of a cross-flow heat exchanger using plain tube and

almond dimple randomly arrangement. Air and Water were the fluids used to carry out test. The objective was to analyse the effect of gas flow over two different tubes. The mass flow rate of air was varied such that the Reynolds number was in between 10000 to 37000. Since the objective is to analyse the performance of gas flow over tubes, the tube side fluid flow condition was kept constant. Comparisons of experimental results for Plain and almond tube when randomly arranged. The overall heat transfer co-efficient is found to increase while using almond shaped dimpled tubes over plain tubes, which is more pronounced at higher Reynolds number. Pressure drop in case of almond dimple tubes is more as compared to plain tube, due to more turbulence. Heat loss is less in case of dimple tubes as compare to Plain tubes this is due to there is more turbulent mixing due to the vortices formed from secondary flows for almond dimple tubes which enhances the heat transfer coefficient and thus results in reduction in heat loss. [8]

CONCLUSION

On the basis of numerical and experimental analysis has been carried out in different studies on effectiveness, overall heat transfer coefficient and friction factors are analyzed on dimple tube. The theoretical results showed that an increase in turbulence intensity could be one of the reasons for higher performance in dimple tube as compared to the plain tube in heat exchanger. Spherical indentations or dimples have shown good heat transfer characteristics when used as surface roughness. The technology using dimples recently attracted interest due to the substantial heat transfer augmentations it induces, with pressure drop penalties smaller than with other types of heat augmentation. From all the literature review, the researchers have used various dimple shaped geometries such as triangular, ellipsoidal, circular, and square out of which ellipsoidal shape gives better results due to prior vortex formation then other shapes.

REFERENCES

- [1] Antony luki.A,Ganesan.M, "Flow Analysis and Characteristics Comparison of Double Pipe Heat Exchanger Using Enhanced Tubes", *IOSR Journal of Mechanical and Civil Engineering (IOSR-JMCE)*, e-ISSN: 2278-1684, p-ISSN: 2320-334X; PP 16-21 www.iosrjournals.org



- [2] Saurabh R Verma, P. M. Khanwalkar, V. N. Kapatkar, "A Review on Heat Transfer Augmentation for Various Dimpled Geometries", *International Journal on Theoretical and Applied Research in Mechanical Engineering (IJTARME)*, ISSN (Print): 2319-3182, Volume -4, Issue-1, 2015.
- [3] ChinarukThianpong , PetpicesEiamsa-ard , KhwanchitWongcharee , Smith Eiamsa-ard, "Compound heat transfer enhancement of a dimpled tube with a twisted tape swirl generator" *International Communications in Heat and Mass Transfer* 36 ,pg698–704, (2009)
- [4] YogeshDilipBanekar,Shashank Ram Bhegade,MayurVasantSandbhor, "Dimple tube heat exchanger", *International Journal of Science, Engineering and Technology Research (IJSETR)*, Volume 4, Issue 5, May 2015
- [5] Pooja Patil, Prof.Padmakar Deshmukh, "An Experimental Study of Heat Transfer Enhancement in the Circular Channel with Almond Shape Dimples", *IOSR Journal of Mechanical and Civil Engineering (IOSR-JMCE)*, e-ISSN: 2278-1684, p-ISSN: 2320-334X, Volume 11, Issue 5 Ver. I (Sep- Oct. 2014), PP 48-57 www.iosrjournals.org
- [6] Hasibur Rahman Sardar, Abdul RazakKaladgi, "Forced Convection Heat Transfer Analysis through Dimpled Surfaces with Different Arrangements", *American Journal of Energy Engineering*, ISSN: 2329-1648 (Print); ISSN: 2329-163X (Online), Pg-3(3): 37-45, 2015
- [7] K.Senthilkumar, P.Palanisamy, R.Vinoth, S.Perumal, "Numerical Study of a Concentric Tube Heat Exchanger Using Dimpled Tubes with Al₂O₃ NanoFluid", *Australian Journal of Basic and Applied Sciences*, Pages: 185-193, 8(7) May 2014
- [8] Shiva K. Vyas, Anand R. Nadgire, Brijesh S. Patil and Sachin R. Kale, "Heat Transfer Augmentation using Almond Dimple Tubes with Random Arrangement", *International Journal of Current Engineering and Technology*, E-ISSN 2277 – 4106, P-ISSN 2347 – 5161 ©2016 INPRESSCO
- [9] Parth P. Parekh, Dr.Neeraj K. Chavda, "Experimental and Exergy Analysis of A Double Pipe Heat Exchanger for Parallel Flow Arrangement", *Parth P. Parekh Int. Journal of Engineering Research and Applications* www.ijera.com ISSN: 2248-9622, Vol. 4, Issue 7(Version 2), pp.09-13, July 2014

Spiritual Research: The Role Of Researchers In Shaping The Society

BK (Dr.) Subhash Chandra
Intercultural Open University (IOU), NL
E-mail address: schandra101@gmail.com

I. INTRODUCTION

This world is a vast Amphitheatre of action in which souls, in their respective bodies, play their various parts. Planet Earth exists in an extremely tiny portion of the physical universe and is governed by well-defined physical, chemical and biological laws. In India, the world, which we inhabit, is called karma kshetra (the field of action), because it is here that we sow the seeds of actions and reap their fruits. It is here that the soul takes on flesh and bones and expresses the role that it has hidden within itself, causing variations in the material environment. The state of the material world at any given moment is a direct reflection of the state of consciousness of the human beings, which inhabit it. If there is peace and harmony within the soul this is reflected in nature. If there is conflict and confusion, nature responds accordingly.

Present Scenario:

The world is in confusion and human beings are driven by the power of egocentric behavior. We are living in a world of crisis, crisis of Humanity, crisis of environmental sustainability crisis of cultural sustainability. Crisis of Humanity includes the – increasing poverty & population and decreasing Peace, Crisis of environmental sustainability means environmental degradation & environmental protection; Crisis of cultural sustainability – includes hatred, intolerance and violence in the society between the people, between the groups, races & between the nations.

With the advent of the year 2001, we have entered a new century and a new millennium, but humanity is standing at the crossroads of all transition processes.

The biggest agenda of 21st century is 'How to save the Humanity'? And how to achieve Peace, Happiness & Harmony in life?

Cycle of time:

The cycle of time also gives us a clue to realize that the world is an eternal system having neither a beginning, nor an end. There was a period in this cycle of time when the human nature was in perfect harmony with the Nature; when peace,

harmony, stability and prosperity was prevalent – this period was known world over as Golden Era (Sathya Yuga). At present we are living in age of fear, conflicts, violence & frustration, which is known as 'Kali Yuga' - Age of darkness, disharmony & imbalance in nature & human nature due to mind pollution. The crisis humanity faces today is not only a crisis of People, Population and Poverty but a crisis of Peace & harmony i.e. disharmony between Man, Nature & Creator.

We must transform the way we think and re-evaluate our priorities & values and revive abandoned but more caring respectful attitudes, values and lifestyles, in relation to nature and humanity as a whole. There is profound transformations are required on many dimensions — personal, environmental, cultural, societal, economical & educational to save the humanity & Mother Earth. To meet these global crisis and to save the Mother earth from further destruction we have to change our thinking & our consciousness & therefore there is great need of Spiritual awakening & self-transformation for building harmonious society.

Understanding Science & Spirituality

Universe we live in is a multidimensional reality, ranging from the subatomic to the supagalactic in the realm of physics alone. Biology, medicine, psychology and the social sciences require different perspectives and approaches to deal with reality appropriately. On top of these are subtle forces and influences, extrasensory, occult and spiritual, that many people claim to experience and have developed special methods of working with.

Science is to discover the physical world i.e. material progress and Spirituality is the science to discover the spiritual world i.e. to discover the inner world for inner peace & happiness.

Today we talk about science: we do some experiment in the laboratory and whatever is observed by the scientist is called as science. But the ... Spirituality is beyond Time, & Space. There are so many things that cannot be observed, like the abstract things, but they can be realized through RajYoga meditation.

Modern science consists of an objective pursuit of truth through observation and experimentation

Material Science & Spiritual Science

“Material Science & Spiritual Science are the two sides of the same coin.

Synergy of the two sides will create a better Peaceful world”.

Spirituality is the science to discover the inner world i.e. to understand self who am I? And to discover the purpose of life? From an Indian perspective, we can call this inner science of Self-knowledge, 'yogic science'. Spirituality aims at the supreme truth, which is eternal, that truth which never changes. It regards relative truths - up to and including the very existence of the external world itself - as ultimately an illusion because these eventually, at one time or level or another, are found not to be valid.

Spiritual Science & Material Sciences - Higher and Lower Sciences: "Two sciences are to be known, the higher and the lower science. The higher is through which the eternal is known." The lower knowledge consists of the outer forms of knowledge through which the transient factors are known, the aspects of name, form and action. The higher knowledge is Self-knowledge through which the nameless, formless being is known

Science is information... Spirituality is Transformation: The time has come to shift focus from information to transformation. Transforming thought process, the sense of ownership and the mind space. The need of the hour is to realize that inner transformation which can lead to inner peace & harmony. When you dedicate yourself to transforming your inner world then your vision shifts from smaller to bigger goals.

How God Designed Us?

We are a 3 Part Whole - Body-Mind- Soul 1. Our Body:

It is by our body that we function. It's comprised of organs and cells which consists of protein carbohydrates and fats. Our body contains our nervous system with nerves and the brain. It's through our bodies that we connect to the physical world with our five senses.

2. Our Mind: The 'Mind' is Power house & creator of thoughts (The ability to think)

Our mind has a conscious part and a subconscious part. The conscious mind is where we do our thinking and reasoning. The subconscious mind is where we hold our deep

beliefs and our attitudes. It's also where we have our feeling, our emotions and retain our memories. Our will is what gives us the ability to make choices. Through a very complex way, our mind, our will and our emotions are connected to the body through our endocrine, nervous and immune systems.

“The mind and body communicate constantly. What the mind thinks, perceives, and experiences is sent from our brain to the rest of the body.” Herbert Benson, M.D., The Benson – Henson Institute for Mind Body Medicine

3. Our Soul

Our Soul is what gives us our personality and it's through our soul that we live out our relationship with God, with other people and with our self. It's in our Soul which gives meaning, direction and purpose in life. At the deepest level our Soul gives us meaning and purpose and our spirit enables us to love one another, our self and God. It's through our spirit that we have communion and fellowship with God.

Spiritual Research - Understanding Inner world?

Every person is a researcher because he/she is engaged in re-searching the inner reality, inner peace, & inner stability. Spirituality is the science of human growth towards the ultimate reality.

Spiritual Research is researching the Inner world “To discover the spiritual identity of self and to discover who am I? And also to rediscover what is the Purpose of my Life? Why am I here on this Earth?

The Gross Reality of the Human Being

Spiritual Research is undertaken to go into the depth of researching the inner world i.e. Spiritual wisdom - knowledge on soul, the Supreme Soul, the eternal world drama, the law of karma and world transformation through the process of Raj Yoga Meditation for self-transformation

Human Being consists of two parts: Physical Part (Matter) & Spiritual Part (Spirit).

Physical Part (Matter) is called as physical world & Spiritual Part (Spirit) is known as inner world.

- HUMAN BEING= HUMAN + BEING = BODY(Matter) + SOUL(Spirit)
- BODY = FIVE GROSS ELEMENTS OF NATURE (earth, water, fire, air and space) =Atoms – Molecules – Elements + Compounds (organic and inorganic) = CELLS- TISSUES- ORGANS- SYSTEMS = BODY

THE INNER REALITY (SOUL) - Soul or the 'being' is the real person

- It expresses itself through its subtle faculties – mind, intellect and latencies (Sanskar's).
- Soul is composed of seven basic attributes or meta-physical energies – knowledge, peace, love, joy, purity, power and bliss.
- Mind is the Emotional self and Intellect is the rational self.

Spiritual Research for Enlightenment:

Awakening ~ Discovering~ Understanding~ Transformation & Enlightenment for Peace & happiness

"Spirituality is an understanding of consciousness that allows you to experience everything in its contextual and rational nature." Said Deepak Chopra - A Spiritual Guru

Spirituality is the science of human growth towards the ultimate reality. Human Being consists of two parts: Physical Part (Matter) & Spiritual Part (Spirit). Spirituality is a 'process of transforming the consciousness from lower (Impure) consciousness to higher consciousness (pure) through the process of Rajyoga meditation'.

The Spirit or Soul is the- Source Of Unique Light .Spirit manifests itself through body (matter). Spirit brings meaning to matter, and matter gives form to spirit. We are human body and human spirit at the same times. The spiritual quest is one that emphasizes a dynamic process in which one purposefully seeks to discover his or her potential, ultimate purpose, and personal relationship with a Higher Power or Being that may or may not be called God. The Spirit or Soul is the reservoir of Gyan (Wisdom) & Shakti (Energy). What is Soul? Soul = Source Of Unique Light.

Your soul is the source of Creativity, intuition, vision & understanding and all possibilities.

Five Steps of Spiritual Research:

- 1st Step Awakening self with Brahma Kamari's.
- 2nd Step Discovering: To Re-discover the self-spiritual identity i.e. To discover who am I?
- 3rd Step Understanding: To Understand your soul's purpose. To discover the purpose of Life why I have come on this Earth?

Some people are having the goals of creating the wealth & building relationships & developing new relationships to achieve happiness as purpose of life. Others have to serve the society through social service and some are having

higher purpose of life- 'selfless service'- i.e. service to humanity. My purpose of Life is to spread Peace, Happiness & Prosperity through Love, Peace &

- 4th Step Transformation (Self Transformation through RYM)

Inner Transformation From -ve Thoughts to +ve Thoughts; and From -ve Emotions (Anger, Greed & Ego) to +ve Emotions (Peace, Love & Cooperation) & From Body Consciousness to Soul Consciousness.

- 5th Step Enlightenment for Peace & Harmony (Realization of Oneness with Divine Consciousness i.e. Shiv Baba)

What is Soul? Soul -The Spirit or Soul is the-Source Of Unique Light .Spirit manifests itself through body (matter). Spirit brings meaning to matter, and matter gives form to spirit. We are human body and human spirit at the same times. The spiritual quest is one that emphasizes a dynamic process in which one purposefully seeks to discover his or her potential, ultimate purpose, and personal relationship with a Higher Power or Being that may or may not be called God. The Spirit or Soul is the reservoir of Gyan (Wisdom) & Shakti (Energy). Your soul is the source of Creativity, intuition, vision & understanding and all possibilities

Seven Qualities (meta-physical energies) of the Soul

S.O.U.L – Source Of Unique Light

Spirituality is a process of transforming the consciousness from lower (Impure) consciousness to higher consciousness (pure) through the process of self-transformation. The soul is made up of seven meta-physical energies that are described as the basic or primary attributes – BLISS, TRUTH (KNOWLEDGE), PEACE, LOVE, JOY, PURITY and POWER - of the soul. These attributes are filled in the sub-conscious mind called Sanskaras in Hindi, and are expressed through the faculties of mind and intellect that together constitute the conscious mind. There are seven Qualities of Soul, which are represented by seven colors of Rainbow i.e. VIBGYOR.

Colour Energy Quality of Soul

- VIOLET Spiritual Energy Bliss (Joy)
- INDIGO Vision Energy Truth (Knowledge)
- BLUE Communication Energy Peace
- GREEN - Transformation Energy Love
- YELLOW Emotional Energy Happiness

- ORANGE Creative Energy Purity
- RED - Primitive Energy Power

Spiritual Research for building a Harmonious Society

Everything starts with the state of the self and then radiates to the body, relationships, society, environment & the World.

God has given a beautiful BODY as a Gift to us to fulfill the purpose of Life on this earth. Therefore firstly we have to Re-discover the self-spiritual identity i.e. To discover who am I? And to discover the purpose of Life why we have come on this Earth? Then follow the path of Karma's in this physical world to fulfill the contract by finishing the purpose of Life on this earth.

1. Purpose of Life – Firstly we have to discover the purpose of Life why I have come on this Earth to fulfill the contract? And also to discover self- who am I? Some people are having the goals of creating the wealth & building relationships & developing new relationships to achieve happiness as purpose of life. Others have to serve the society through social service and some are having higher purpose of life- 'selfless service'- i.e. service to humanity. My purpose of Life is to spread Peace, Happiness & Prosperity through Love, Peace & Cooperation.

2. **Time:** We have entered into New Year 2013. The year 2011 was the year of Change for creating new ideas. The year 2012 was the year of Transformation and the year 2013 is the Year of rediscovering self and the year of self-Transformation from impure (Body) consciousness to pure (soul) consciousness to achieve the purpose of life.

3. Physical body: The Physical body is the physical field, given as a gift from the God for doing karmas (actions) in physical world. Our body is having the five senses to perform the actions in the physical world. Through these five senses we perform our karmas (actions) in this world and depending upon the quality of our karmas we experience pleasure & pain, success & failure, happiness & unhappiness.

4. **Soul is the inner field-** to discover who am I? & to understand your soul's purpose i.e. to discover the purpose of Life why I have come on this Earth?

Inner dynamics - Mind, Intellect and Sansakar's (MIS) system

The human mind is the most creative, powerful and wonderful "instrument" we possess. Using this energy called mind we have been able to search the deepest oceans, send humans to the

moon and scan the molecular fabric of the building blocks of nature. But have we found our true self? We have become the most educated and civilized society in our history, but are we civil towards each other?

The Soul consists of three main faculties through which soul or spirit performs all the mental activities:

1. The 'Mind' –Power house & creator of thoughts (The ability to think)

2. **The 'Intellect'** –Decision maker (The ability to judge & discriminate between Right & wrong).

3. The 'Sanskaras' (Subconsciousness) - The ability to retain impressions of the past thoughts in the form of attitudes, modes of habits.

2. The 'Mind' –Power house & creator of thoughts (The ability to think) - Mind is a field of thoughts – As you sow shall you reap. Your mind is a field of thoughts always creating thoughts & feelings, forms ideas etc. The mind is a very powerful faculty which constantly engaged in a conversation about what happened in the past, what is happening now, and what may happen in the future. Your thoughts, memories, desires, and feelings are expressions of your mind.

(i) Positive Thoughts leads to Positive feelings which create positive conditioning which develops positive attitudes and leads to positive actions.

(ii) Negative Thoughts leads to negative feelings which create negative conditioning which develops negative attitudes and negative attitudes leads to negative actions.

2. The 'Intellect' –Decision maker (The ability to judge & discriminate between Right & wrong). Your actions depend upon the quality of decision. The 'Intellect' gives you the direction to select the decision – Right Decision or wrong decision. Right Decision leads you to the Right actions (*Shubh Karmas*) or wrong decision leads you to the wrong actions(*Ashubh Karmas*)

3. The 'Sanskaras' (Subconsciousness) - The ability to retain impressions of the past thoughts in the form of attitudes, modes of habits. All the actions get registered or filed in the subconsciousness or Sanskaras as the records of the self in the form of experiences, habits, traits, talents or memories and as a result forms our personality.

7-Steps to Self-Transformation (Self-Transformation leads to World Transformation)

Know the change you want to make or habit you want to change (ask yourself what behavior, emotions and feelings I want to change or what I wish to do differently-Make a list). Make the commitment to change. For example, I became aware of my unhealthy eating habits and made the conscious decision to change them.

1. 1st step is Pure Consciousness - Developing positive state of Mind by developing Sattavik pure consciousness i.e. purity in thoughts & purity in actions.

Think positive & act positive: Our physical reality is shaped by our thoughts & our karmas (actions). Positivity and states of being positive are direct effects of raising & transforming your consciousness.

2. 2nd step is Understanding self – who am I? And understanding Creator (God) & understanding Nature.

3. 3rd step is Connecting yourself with Universal Energy (Supreme Soul) for receiving inner guidance & inspiration.

4. 4th step is the Respect of Holistic Mind Management for building Harmonious society. Respect means – Giving Respect to self, Creator & Mother Earth for building Harmonious society.

5. 5th step is Recharging the Mind i.e. renewing the Spirit through Raja Yoga Meditation to achieve Inner Peace & harmony.

6. 6th step is the Transformation of Consciousness i.e. From impure Consciousness (Body consciousness) to Pure Consciousness (Soul Consciousness).

7. Finally 7th step of Holistic Mind Management is Manifestation of Peace & Harmony i.e. Enlightenment (Self-realization).

Conclusion: Choose the Path ~Choose your life
We have to choose the path of the Life from the following two paths :

1. Material Path – Path of material growth & development

2. Spiritual Path - Path of Spiritual growth, inner peace & Enlightenment.

To conclude we must follow the Spiritual Path - 'PURITY 2100' i.e. Path of Purity for Peace & Happiness

'PURITY' - Model of Self Transformation

- P - Be Pure (Purity in thoughts, in words & actions)
- U - Universal Energy (Connect your self with Universal Energy (Supreme Soul) for receiving inner guidance & inspiration.
- R – Recharging the Mind i.e. (Renewing the Spirit through Raja Yoga Meditation).
- I – Inspiration & Intuition (Receiving the inspiration & intuition)
- T- Self-Transformation (self-transformation leads to World Transformation).
- Y- Yoga for Enlightenment (Self - realization).

Meditation enables you to embark on this inward journey. Raja Yoga meditation gives you a clear spiritual understanding of yourself, helps you re-discover and use the positive qualities already latent within you, enables you to develop your strengths of character and create new attitudes and responses to life.

- 'Vasudheva Kutumbkam' – One World - One Family

In western thought 'Globalization' is the term for production & profit by using physical resources because World is one market. In Indian philosophy 'Vasudheva Kutumbkam' - The world is one family has been expressed in our scriptures. The oneness of humanity has been a fundamental belief of Indian Civilization. Global Peace is Oneness of Humanity. World Peace & oneness of Humanity can only be achieved through inner Peace & self-transformation through RajYoga meditation.

OM-Shanti i.e. I am a peaceful soul.

'Self-peace leads to world transformation.'

Strength Appraisal of Blended Concrete

Lomesh S. Mahajan¹, S.R.Bhagat², S.M.Pore³
Dept. of Civil Engineering

¹Research Scholar in Dr. Babasaheb Ambedkar Technological University, Lonere, (M.S.), India.
^{2,3}Associate Professor in Dr. Babasaheb Ambedkar Technological University, Lonere, (M.S.), India.
¹Loms786@gmail.com, ²srbhagat@dbatu.ac.in

ABSTRACT:

Concrete plays significance role in the construction industry. All over the world second largest consuming construction material used as concrete rather than water. In the blooming of construction industry blended cement used with supplementary of material like fly ash, slag, metakaolin, because of considerably cost, effectively and sustainability. Today's industrial environment is competitive, it is well known fact thermal power plant wastes causes so many destruction and produces bad impacts on nations economics. The current challenge of concrete industry is to produce high strength and workability supporting material. The use of fly ash enhances durability of concrete and life at effective cost. Fly ash effectively minimizing the quantity of cement content in concrete mix, as one tone of cement saved will reduce an equal amount of CO₂ to be discharged into atmosphere. It was also found since last 2-3 decades that utilization of calcined clay in the form of metakaolin (MK) as a supplementary for mortar and concrete has acceptable interest along with fly ash. In this study evaluate the feasibility of supplementary material in the form of flyash and metakaolin for M20 grade of concrete.

Keywords - Fly ash, metakaolin, cement, concrete, M20.

I. INTRODUCTION

An increasing global pollution has forced many researchers to find more eco- friendly methods for waste elimination. Concrete is apparently the most vastly used construction material all over the globe. The supplement of material admixture with various amount of cement has desperately grown along with blooming of construction industry, because of

considerably cost, sustainable environment and to protect green energy.

Though it is almost impossible to fully recoup the damage caused by cement but it is possible to minimize the potential risks on environment if fly ash used as supplementary to cement. In last couple of years some difficulties came in to picture which results in development of country.

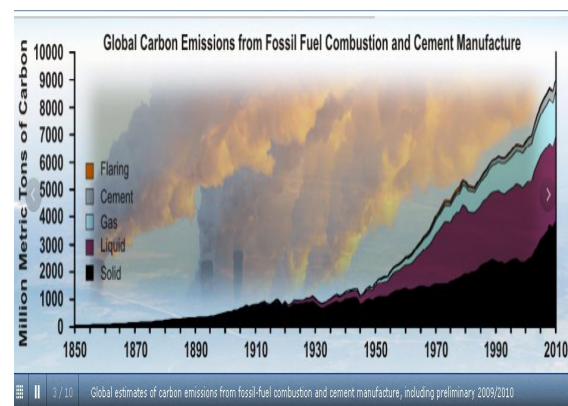

Figure: 1 Global carbon emissions from fossil fuel combustion and cement manufacture

The Carbon dioxide information analysis center (CDIAC), observing ecosystem level and exchange of CO₂. The graphs has indicates the rising phenomena in the global carbon emission from fossil fuel combustion and cement manufacture as shown in figure no 1.

The waste by product obtained from thermal power station is residue from combustion of pulverized coal is known as fly ash. To achieve material of cementing properties, it is combined with lime. In India at the present status, fly ash production has over 160 million ton per annum. Similarly other countries also affected by productivity of fly ash waste. It shows about 12% to 13 % of the whole

world consumption. Now the present challenge for concrete industry is to produce high strength and durable supporting material. The use of fly ash enhances durability of concrete and life at effective cost. The concrete production affects badly to the environment. So, to overcome the challenge following ways are effective.

- By minimizing the quantity of cement content in concrete mix.
- As one tone of cement saved will save an equal amount of CO₂ to be discharged in to atmosphere. Cement production also growing 2.5% annually and may be reaches in between 4.0-4.4 billion tons by 2050. India produces 280 million metric tons of cement annually. Even ten percent saving will reduce 10 million tons CO₂ to be discharged to atmosphere.
- By reducing the use of natural fine and coarse aggregates which source of supply are limited and are producing very rapidly.
- By focusing ultimate possible alternative materials like fly ash in concrete as it will minimize demand of landfill spaces for dump problem of such waste materials.

Therefore enforcing the use of by-products for replacement of cement may effectively use in this challenging scenario. calcined clay is one available source for a pozzolana. From the thousands of years pozzolans used in the form of calcined kaolinite clay with lime have been used to produce cementitious materials. The objective of this Study is to report supplementary material which can be used as part replacement of cement in concrete.

I. LITREATURE REVIEW

Patil *et al.* (2012), has indicate that workability and strength of concrete can be improve by addition of metakaolin as a partial replacement. Concrete mixes having fly-ash as cement replacement material (CRM) have lesser cement content, adverse effects related to higher cement content, such as shrinkage, excessive rate of heat development etc., are minimized in the concrete. Use of fly-ash as cement replacement material for low strength concrete beyond 30% level can have enhanced durability and hence long service life.

The replacement of high lime fly ash concrete generally increases the ultimate strength of concrete. So, it is possible that fly ash replace to some extent for achieve design strength. Exposure of addition of HRM has more effective than replacement of HRM in concrete as per compressive strength assessment and improve resistance against sulfate attack (Maroliya, 2012).

Aieswarya S *et al.* (2013) determine of setting time which reduces while metakaolin used as superplastisizer and for control mix it has gives effective result in strength with durability concern. The studies have been conducted on concrete mixes for the particle replacement of cement by fly-ash with 300 to 500 kg/cum with cementing material at 20%, 30%, 40% and 50% replacement level. By using rapid chloride permeability test workability, setting time, modules of elasticity shrinkage, air content, permeability, compressive strength and density for the effect of fly-ash are studied.

The effect of fly-ash on the properties of concrete for M25 grade of concrete are as w/c ratio of concrete increases the slump loss of concrete increases and the ultimate compressive strength of concrete goes on decreasing and the increasing in the quality of fly-ash increases the slump loss of concrete.

Nova John, 2013 conducted various experiment on split tensile strength and concluded variation in observed values of split tensile strength for all mixes. Experimental results shows that if the content of MK crosses threshold of 20% then decreases split tensile strength, with maximum flexural strength for 15% replacement. Metakaoline gives cementitious structural property which enhances mechanical properties in concrete. Metakaoline includes calcium carbonate contents which help to create reaction with alumina and has been used as binding material (Sawant and Ghugal, 2015). In addition of 15% amount of metakaolin has considerably reduce workability but when it is used in below 15% of replacement shows 20% higher strength than regular concrete (Patil *et al.*, 2012). Varma and Ramrao, 2014, investigate the improvement in concrete with potential of meatakaolin for higher grade M70 and detect split tensile strength enhancement maximum at 15%

replacement of cement with metakaolin. The range between 10% to 15% has been found as a more effective amount of replacement for compressive strength (Manikandan *et al.*, 2015).

Experimentally found out chloride permeability for period of hydration 28, 90, 180 days results gives idea for reduces chloride permeability by 10% substitution of metakaolin but increases compressive strength (Marinos *et al.*, 2015). Ahmad *et al.*, (2014) suggested fully exploit fly ash suitable for higher compressive strength. Blended cement with metakaolin helps where durable concrete needed in influence of salt attack (Abbas *et al.* 2010).

II. MATERIALS AND METHOD

For the mix of concrete Ultra Tech 53 grades OPC is used. This cement is the mostly used in the construction industry across India.

Maximum size of Coarse aggregates is 20 mm used for this study which taken from Jalgaon district, Maharashtra..

A. FLY ASH

Fly ash is a waste product of the electric power generating industry. It is removing from the flue gases of coal burning power station in order to prevent serious air pollution problems. Fly ash is formed from the incombustible component in the fuel and from material unburdened because of incomplete combustion. The majority of fly ash collected is coal –derived, but fly ash may also be produced by the combustion of wood. Figure 2 shows the some minor hump particle also in fly ash while doing experimental work.



Fig No. 2: Sample of fly ash

B. METAKAOLIN

The calcined clay in the form of Metakaolin (MK) as a pozzolanic used as a supplementary to cement replacement to prepare concrete. In the fig 3 shows, particle size of metakaoline is finer than cement but not to extent of slag. It enhances compressive strength and good supplementary for improving durability.



Fig No.3 Metakaolin

III. EXPERIMENTAL

The mix design proportion evaluated for control mix is shown in table 1.

Table1: Mix design proportions (control mix)

Water (litre)	Cement (kg)	F.A. (kg)	C.A. (kg)
197	395	592	1230
0.5	1	1.51	3.12

For mixing coarse aggregates of 20 mm was added in rotating drum type mixture followed by addition of sand and then cement. Concrete mixture for control mix, different proportions of metakaolin and fly ash were used for replacement of cement. The mix design was selected for w/c ratio 0.5.

The M20 grade of concrete should prepare for casting. The fineness modulus of coarse aggregate and fine aggregate are determined. The tests like specific gravity, water absorption of coarse aggregates, natural sand, Metakaolin and fly ash performed in laboratory. The split tensile test performed in accordance with IS: 5816-1970. The

flexural test performed in accordance with as per BS 1881: Part 118: 1983.

For observation remarks 4 cubes, 4 cylinders and 4 beams specimen were casted and tested for 7days and 28 days as shown in fig no 4. Concrete cubes of size 150 mm × 150 mm × 150 mm were cast with and without Fly ash And Metakaoline.

The beam specimen of size 100 mm × 100 mm × 500 mm is tested for single point load at the midpoint under the UTM of capacity 100 ton. The specimen of size 150 mm in diameter and length of 300 mm is casted and tested under the manual CTM of capacity 300 ton. The specimen is kept under CTM at the center with play wood at top and bottom.



Fig No.4: Experimental Specimen

IV. RESULTS AND DISCUSSION

The maximum load at failure reading was taken and the average compressive strength is calculated. The result shown in table no 2 for all three tests (compressive / Split tensile / flexural) as per laboratory procedure.

Table No.2: Strength assessment for 28days

Replacement	Compressive Strength (N/mm ²)	Split Strength (N/mm ²)	Flexural Strength (N/mm ²)
Ref. Conc.	24.19	3.03	1.80
8%-MK & 20% flyash	21.66	2.48	1.76
7.5% -MK & 15% flyash	27.06	2.74	1.70
7.% -MK & 10% flyash	24.80	2.91	2.10

Ref. Conc.	24.19	3.03	1.80
8%-MK & 20% flyash	21.66	2.48	1.76
7.5% -MK & 15% flyash	27.06	2.74	1.70
7.% -MK & 10% flyash	24.80	2.91	2.10

The relationship between compressive strength and tensile strength has been found to be influenced by many factors, including concrete strength level, coarse aggregates properties, testing age, curing air entrainment. Compressive strength got improve in sample 7.5% MK and 15% fly ash. It shows that we can reduce 23.5% cement in concrete and improve compressive strength, if metakaolin + fly ash used to replace cement. Such blended concrete reduce the load of CO₂ emission from construction industry up to 20%.

GRAPHICAL REPRESENTATION

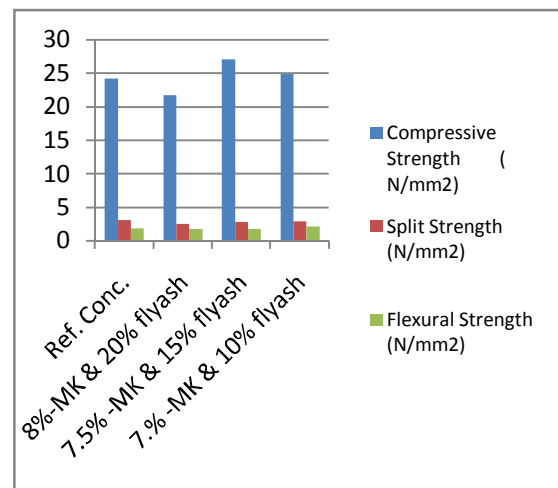

Graph: Replacement α Strength

From graph obtained by experimental works it is seen that combination of for 15% fly and 7.5%

metakaoline is most effective for improving compressive strength.

The split tensile strength for the combination of replacement (7% metakaoline and 10% fly ash) is remaining same.

The flexural strength for (7% metakaoline and 10% fly ash) was increased up to 12% for 28 days.

V. CONCLUSION

In this study experimental results are presented to evaluate the feasibility of utilizing of fly ash and metakaolin cement replacement in concrete with compressive strength of 20 N/mm² for slump as 100 mm ± 10 mm. As a result the ratio of splitting tensile strength to compressive strength decreases with increasing strength.

Conclusions have been drawn that for blended concrete, 7% metakaoline and 10% fly ash is the possible best combination for cement replacement in concrete with respect to flexural strength and 7.5 % MK and 15% fly ash gives better compressive strength. All samples able to satisfy requirement as per IS code. The use of blended concrete has cost effective and more durable as compare to traditional concrete.

REFERENCES

- [1] Patil, B.B., Kumbhar, P.D., "Strength and Durability Properties of High Performance Concrete incorporating High Reactivity Metakaolin," *International Journal of Modern Engineering Research (IJMER)*, 2(3), pp.1099-1104, 2012
- [2] Maroliya, M.K., "A Critical Study on high Reactive Metakaolin Modified Concrete", *IOSR Journal of Engineering*, 2(10), pp.01-04, 2012.
- [3] Das R., Shah P., Sinha I., "Utilization of fly ash as a low cost adsorbant for treatment of textile dyeing industry effluents: Kinetics and Isotherms", *International Journal of emerging technology and advanced engineering*, volume 5, Issue 2: pp.543-548, Feb 2015.
- [4] Varma Geetha v., Singh R. K., Shahu Vaishali, "A comparative study on the removal of heavy metals by adsorption using fly ash and sludge: A Review, *International journal of application or Innovation in engineering and management*, Volume 2, Issue 7: pp.45-56, July 2013.
- [5] Aiqin Wang, Chengzhi Zhang, Wei Sun, "Fly ash effects: I. The morphological effect of fly ash", *Cement and Concrete Research* 33 (2003) 2023-2029.
- [6] Sarath Chandra Kumar, Bendapudi & P. Shah, "Contribution of fly ash to the properties of mortar and concrete", *International Journal on Earth Science & Engineering*, ISSN 0974-5904, Volume 04, No.06 SPL, pp.1017-1023, October 2011.
- [7] P. R. Wankhede, V. A. Fulari, "Effect of fly ash on properties of concrete", *International Journal of Emerging Technology and Advanced Engineering (IJETA)*, ISSN 2250-2459, ISO 9001:2008 Certified Journal, Volume 4, Issue 7, July 2014.
- [8] Maninder Kaur, Manpreet Kaur, "A review on utilization of coconut shell as coarse aggregate in mass concrete", *International Journal of Applied Engineering Research*, ISSN 0973-4562 vol. 7 No.11 (2012).
- [9] B. Damodhara Reddy, S. Aruna Jyothy, Fawaz Shaik, "Experimental analysis of the use of coconut shell as coarse aggregate", *IOSR Journal of Mechanical and Civil engineering (IOSR-JMCE)* e-ISSN: 2278-1684, p-ISSN: 2320-334X, Volume10, Issue 6 (Jan. 2014), PP 06-13.
- [10] Sreenivasulu Dandagala, Praveen K, Satish K, Sri Harsha K, Mahesh V, Anil Kumar p, "Laboratory investigation on coconut shell in concrete: An alternative low cost building material", *National Conference on Green Engineering and Technologies for Sustainable Future-2014, Journal of Chemical and Pharmaceutical Sciences*, ISSN: 09744-2115.
- [11] Vanita Aggarwal, S. M. Gupta and S. N. Sachdeva, "High volume fly ash concrete: A green concrete", *Journal of Environmental Research and Development*, Vol. 6 No. 3A, Jan-March 2012.
- [12] Girish C.R., Murthy V.R., "Adsorption of phenol from wastewater using locally available adsorbants", *Journal of Environmental research and development*, Volume 6, No. 3A: pp.763-772, Jan- March 2012,
- [13] Gaikwad Samiksha., Mane S. J., "Reduction of Chemical Oxygen Demand by using coconut shell activated carbon and sugarcane bagasse fly ash," *International Journal of Science and research*, , Volume 4, Issue 7: pp.642-645, July 2015.
- [14] Mohammad M.A., Shitu A., Tadda M.A., Ngabura M., "Utilisation of various agricultural waste materials in the treatment of Industrial waste water containing heavy metals: A review," *International Research Journal of Environmental Science*, Volume 3, Issue 3: pp.62-71, March 2014.
- [15] Agbozu I. E., Emoruwa F. O., "Batch adsorption of heavy metals (Cu, Pb, Fe, Cr and Cd) from aqueous solution using coconut husk ," *African Journal of Environmental Science and technology*, Volume 8, Issue 4: pp.239-246, April 2014.
- [16] Sawant, R.M., Ghugal, Y.M., "Recent trend: Use of metakaolin as admixture: A review", *American Journal of Engineering Research (AJER)*, 4(12), pp.08-14, 2015.
- [17] Patil, S.N., Gupta, A.K., Deshpande, S.S., Metakaolin-Pozzolanic Material For Cement in High Strength Concrete, *IOSR Journal of Mechanical and Civil Engineering (IOSR-JMCE)*, ISSN: 2278-1684, pp.46-49. 2012.
- [18] Varma, D.V., RamaRao, G.V., "Influence of Metakaolin in High Strength Concrete of M70 Grade for Various Temperatures and Acidic Medium", *IOSR Journal of Mechanical and Civil Engineering (IOSR-JMCE)*, ISSN: 2278-1684, (11)3, pp. 32-37, 2014.
- [19] Manikandan, C., Subalakshmi, R., KarthikRaja, S., Kumar. S., "Development of high strength concrete by using metakaolin and Copper slag", *Journal of Chemical and Pharmaceutical Sciences*, ISSN: 0974-2115, 8(4), pp.928-936, 2015.
- [20] Aiswarya, S., Prince, A.G., Dilip, C." A Review on use of metakaolin in concrete", *IRACST-Engineering Science and Technology: An International Journal (ESTIJ)*, ISSN: 2250-3498, 3(3), pp.592-597, 2013.
- [21] Mahajan L.S., "Comparative analysis for suitability of fly ash and coconut husk in BOD and COD removal from paper mill waste water", *PratiBha: IJSSBT*, ISSN: 2277-7261, Vol.4, No. 2, May 2016, pp.52-59.

Transforming Education and Mobile Internet Connectivity: A pilot study

Dr. Saroj B Patil

Asst. Prof, MBA. SSBT's College of Engineering and Technology, Jalgaon.

Email: sarojpatil74@rediff.com

ABSTRACT:

This paper focused on internet connectivity, e-education through mobile phone. This approach enhances the reach of education in many folds. It results a effective learning tool.

INTRODUCTION:

As more people around the world gain access to all the tools of the digital age, the internet will play a greater role in everyday life. And so far, people in emerging and developing nations say that the increasing use of the internet has been a good influence in the realm of education, personal relationships and the economy. But despite all the benefits of these new technologies, on balance people are more likely to say that the internet is a negative rather than a positive influence on morality, and they are divided about its effect on politics.

Once online, internet users in emerging and developing nations have embraced socializing as their most preferred type of digital activity. Majorities of internet users in all countries surveyed with large enough sample sizes to analyze say they stay in touch with friends and family online. Many also use cyberspace for getting information about politics, health care and government services. Less common are commercial and career activities, such as searching or applying for a job, making or receiving payments, buying products and taking online classes.

On the other part a person won a smart phone and he told the digital drive team that he is not

even aware of who listed him on internet. This is an example of the way telecommunication sector is transforming life of people even if they are unable to use services. Easing life of people by cutting down on distance and enabling them to utilize their time more efficiently can be seen as main reason behind the growth of Indian telecom sector. Government efforts to bring most of services on internet eased life of people like booking of train tickets, birth certificate, and filling police complaints online, online banking services, payment of bills for various utilities. The last two years have seen most of services coming on to mobile phones. The e-commerce sector has further brought people closer to the internet. Now merchant in small towns have customers across globe and are selling product online. People in small town are able to order quality products especially of brands that are not available in their areas. Even small merchant, handicraft traders, local service providers use mobile application like whatsapp, Hike, Face book etc to discover market for themselves.

The number of projects exploring the potential of mobile phone-facilitated m-learning in the developing world is steadily growing, in part by the use of

Figure 1: Wired Virtual Learning Environment of Today.

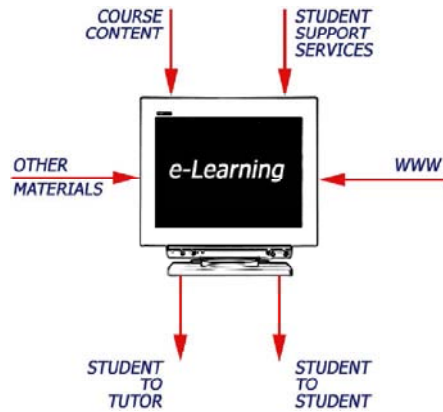

The study seeks to put in place a new virtual learning environment which might be represented thus:

Figure 2: Wireless Virtual Learning Environment of Tomorrow

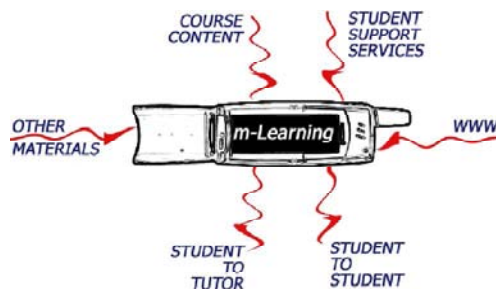

mobile technology in the educational sector in the developed world which has expanded from short-term trials on a small scale to large-scale integration. However, there remains a lack of analysis that brings together the findings of the rising number of mLearning projects in the developing world.

The Role of Mobiles in Improving Access to Education

In theory, mLearning increases access for those who are mobile or cannot physically attend learning institutions – those who would not

otherwise be able to follow courses in a traditional educational setting due to the constraints of work, household activities, or other competing demands on their time. mLearning makes education more accessible in that it enables learners to pursue their studies according to their own schedule. The portability of mobile technology means that mLearning is not bound by fixed class times, mLearning enables learning at all times and in all places, during breaks, before or after shifts, at home.

Mobiles can also supposedly facilitate knowledge-centered learning by providing efficient and inventive methods by which students can learn with understanding meaning that they deepen their understanding of a specific subject matter rather than merely memorizing large amounts of information – and then use this knowledge as a basis for new learning through integration and interconnection. Mobile devices make possible assessment-centered learning as well by enabling the provision of continual feedback throughout the learning process, presenting learners with diagnosis and formative guidance as to what might be improved or what might be learned next

OBJECTIVES OF THE STUDY

The objectives of this present study is to find out how the mobile internet connectivity helps the students in their education and understanding, solving their difficulties in particular subjects deeply and make effective use of internet education within short period of time and also use their knowledge and skills for best results in their academic performance.

METHODOLOGY OF THE STUDY

The research design for the study is exploratory in nature. The responses of the students were through by interviewing personally and discussing with them. By the survey of 100 students were selected as a sample size from an educational college in Jalgaon.

RESULT AND DICUSSION

Respondents indicated that the students using internet and mobile for education has greater advantages and helpful for the student to solve their difficulties in studies. It is observed that students using mobile and internet before and after significant is calculated value of $t(0.0001)$ is less than critical value (0.005). Therefore it can be concluded that students has got more benefit by using mobile and internet connectivity in their education.

FINDINGS

It is found that 85% of students are using mobile and internet connectivity for their studies. They found very easy method for searching topics from their particular subjects in short period of time without wasting time they can also listen and watch the expert lectures from any university or colleges from worldwide by sitting in their home or anywhere. Also downloading the notes, presentation for detail study and also get their doubts and difficulties cleared at any time anywhere even on android mobiles they can also used for this purpose.

Table 1: Comparison of students Before and After using Mobile internet connectivity for education

Student using mobile and internet connectivity	Student not using mobile and internet connectivity	t-value
85%	15%	0.0001

The lack of not using internet facilities students are less as compare to the students using internet connectivity for education. Students get free from their students immediately by using all online learning process it make quicker and easier access to the students.

Fig 3: Graph Showing Results

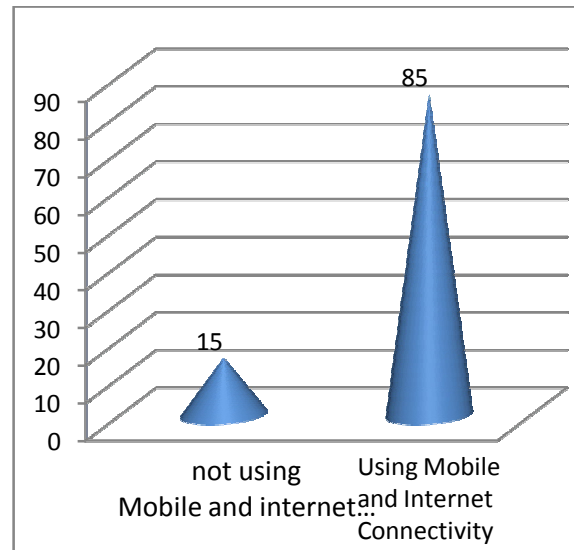

REFERENCES

1. March – 2010,Using Mobile Phones to Improve Educational Outcomes: An Analysis of Evidence from Asia. John-Harmen Valk, Ahmed T. Rashid, and Laurent Elder Pan Asia Networking, IDRC, Canada.
2. Mobile Learning for Education: Benefits and Challenges .Yousef Mehdipour. *Osmania University, Hyderabad, India*
3. The acceptance of mobile wireless Network based widget for sustaining Learning in higher education . Satar habeb, rozinah jamaludin, Penang, Malaysia.
4. Analysis of Student Attitudes towards E-learning: The Case of Engineering Students in Libya Amal Rhema ictoria University, Melbourne, Victoria, Australia
5. Mobile Learning Update. Learning Consortium Perspectives. 2008. pp. 3, 5–13, 17. Retrieved June 9, 2009.
6. Moore, J. (2009). "A portable document search engine to support off-line mobile learning". Proceedings of IADIS International Conference Mobile Learning. Barcelona, Spain.



**PRATIBHA : INTERNATIONAL JOURNAL OF SCIENCE,
SPIRITUALITY, BUSINESS & TECHNOLOGY (IJSSBT)**

Vol. 5, No. 1, December - 2016

ISSN (Print) : 2277-7261

ISSN (on-line) : 2278-3857

[http : www.ijssbt.org](http://www.ijssbt.org)



SHRAM SADHANA BOMBAY TRUST'S
**COLLEGE OF ENGINEERING & TECHNOLOGY,
BAMBHORI, JALGAON (INDIA)**



ISSN 2277-7261